

Machines
and Tools
for Pipework

01/2018

Promotion

LI-ION
22V



NEW
REMS Mini-Press S 22V ACC
Super light, super small,
super handy, ultra fast.
Pressing under 4 s! (see page 25)
Li-Ion 22V Technology

REMS

for Professionals

REMS App – All product information available any time, anywhere* – quickly and easily.

On the building site or at your dealer: All operating instructions, parts lists, product information, product films and more can be called upon immediately. Many other functions are also available to you.

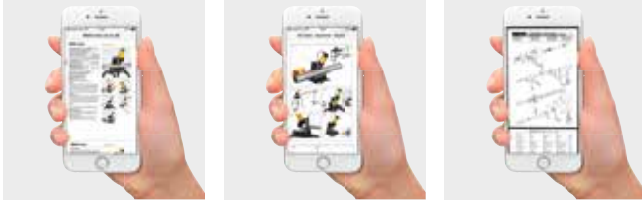

Scan product logo

Are you standing in front of a REMS product? Just scan the product logo and you will get all the product details.

Scan product illustration

You can scan the product illustrations in our offer brochures and get all the details about the product.

Scan QR code

You can scan the REMS QR code and get all the details about the product.



REMS App

Free application software from the Apple App Store or Android App at Google Play.



REMS Multi-Push – just one device with more than 10 automatically running flushing and pressure testing programs. Patent EP 2 816 231 pending!

Permanent process monitoring.

Logging.

USB interface.

EN 806-4
ZVSHK⁽¹⁾
DVGW⁽²⁾

Flushing

Flushing of drinking water installations with water or with a water/air mixture with intermittent compressed air in accordance with EN 806-4:2010 and information leaflet T 84-2004 "Flushing, Disinfection and Commissioning of Drinking Water Installations" (August 2014) of the German Central Association for Sanitary, Heating and Air Conditioning (ZVSHK) and for flushing of radiators and area heating systems. Also for flushing pipe systems with a water/air mixture with constant compressed air.

Disinfection

REMS V-Jet TW disinfection unit for disinfection of drinking water installations in accordance with EN 806-4:2010 and information leaflet "Flushing, Disinfection and Commissioning of Drinking Water Installations" (August 2014) of the German Central Association for Sanitary, Heating and Air Conditioning (ZVSHK) and other pipe systems, as an accessory. REMS Peroxi Color, consisting of a 1 l bottle of REMS Peroxi dosing solution for disinfection of approx. 100 l line volume and 20 ml bottle of red REMS Color dye for dyeing the dosing solution for filling and wash-out check, pipette for checking the effectiveness of the dosing solution (page 103). Feeding of the disinfectant solution without additional dosing pump (Patent EP 2 954 960 pending).

Cleaning and preservation

REMS V-Jet H cleaning and preservation unit for cleaning and preserving heating systems, as an accessory. Cleaner, dyed green for filling and wash-out check and corrosion protection, dyed blue for filling check, for approx. 100 l line volume respectively. Feeding of cleaner and corrosion protection without additional dosing pump (Patent EP 2 954 960 pending).

Pressure testing with compressed air

Leak testing of drinking water installations with compressed air according to information leaflet "Leak Testing of Drinking Water Installations with Compressed Air, Inert Gas or Water" (January 2011) of the German Central Association for Sanitary, Heating and Air Conditioning (ZVSHK), leak testing of gas installations with compressed air according to the technical rule "DVGW-TRGI 2008, Technical Rules for Gas Installations – DVGW Worksheet G 600" of the German Gas and Water Association (DVGW) and leak testing of other pipe systems and vessels with compressed air.

Load testing of drinking water installations with compressed air according to information leaflet "Leak Testing of Drinking Water Installations with Compressed Air, Inert Gas or Water" (January 2011) of the German Central Association for Sanitary, Heating and Air Conditioning (ZVSHK), load testing of gas installations with compressed air according to the technical rule "DVGW-TRGI 2008, Technical Rules for Gas Installations - DVGW Worksheet G 600" of the German Gas and Water Association (DVGW) and load testing of other pipe systems and vessels with compressed air.

Pressure testing with water

REMS Multi-Push SLW with hydro-pneumatic water pump for hydrostatic pressure testing of drinking water installations with water in accordance with EN 806-4:2010, test method A, B or C or test method B, modified in accordance with information leaflet "Leak Testing of Drinking Water Installations with Compressed Air, Inert Gas or Water" (January 2011) of the German Central Association for Sanitary, Heating and Air Conditioning (ZVSHK) and for pressure testing of other pipe systems and vessels.

Compressed air pump

Compressed air pump for controlled filling of all types of vessels with compressed air ≤ 0.8 MPa/ 8 bar/116 psi, with automatic switch-off on reaching the preset air pressure, e.g. for pumping up expansion vessels or tyres.

Operation of compressed air tools

Connection for compressed air tools up to an air requirement ≤ 230 Nl/min, adjustable, for adaptation to the used compressed air tool. Pressure gauge for controlling the air pressure supplied by the compressed air tank. Pneumatic hose with quick coupling DN 7.2, as an accessory.

Logging

Results of the flushing and test programs are saved with date, time and log number in the selected language and can be transferred to USB stick or printer for documentation. Additions to saved data, e.g. customer name, project number, tester, are possible on external devices (e.g. PC, laptop, tablet-PC, Smartphone).



Pressure testing with water



Flushing of radiators and area heating systems



Flushing of drinking water installations



Disinfection of drinking water installations

REMS Multi-Push SL Set

Electronic flushing and pressure testing unit with oil-free compressor. For flushing with water or a water/air mixture, disinfection, cleaning, preservation of pipe systems, for pressure testing of pipe systems and vessels with compressed air, as a pneumatic pump for controlled filling of all types of vessels with compressed air $p \leq 0.8$ MPa/8 bar/116 psi, and for operation of pneumatic tools ≤ 230 Nl/min. Input and control unit. Piston compressor with crank drive, capacitor motor 230 V, 50 Hz, 1,500 W, person circuit breaker (PRCD). Mobile tubular steel frame. Fastenings for water inputs and outputs of the REMS Multi-Push. Two $\varnothing 1"$ suction/pressure hoses, with fabric inlay, 1.5 m long, with 1" hose screw fittings, with caps. One $\varnothing 8$ mm compressed air hose, 1.5 m long, with quick coupling DN 5 and $\frac{1}{2}"$ hose screw fitting, for pressure testing with compressed air. Connecting hose compressor/water connections, 0.6 m long, with quick coupling DN 7.2 and 1" hose screw fitting, 1" double nipple, for blowing out water remains from REMS Multi-Push and suction/pressure hoses at the end of work. Without disinfection unit, without cleaning and preservation unit. In a carton.

Art.-No. 115610 R220 £ 2,470.00

+ Starter-Set TW-H

- 1 REMS V-Jet TW
- 2 REMS Peroxi Color
- 1 REMS V-Jet H
- 2 REMS CleanH
- 2 REMS NoCor

Value £ 741.80

£ **1,989.00**

Art.-No. 1156X1 R220 £ **2,199.00**

REMS Multi-Push SLW Set

Same as REMS Multi-Push SL Set, Art. No. 115610, additionally with hydro-pneumatic water pump and one high-pressure hose $\varnothing \frac{1}{2}"$, 1.5 m long, with $\frac{1}{2}"$ hose screw fittings, with caps, for pressure testing of pipe systems and vessels with water. In a carton.

Art.-No. 115611 R220 £ 3,080.00

+ Starter-Set TW-H

- 1 REMS V-Jet TW
- 2 REMS Peroxi Color
- 1 REMS V-Jet H
- 2 REMS CleanH
- 2 REMS NoCor

Value £ 741.80

£ **2,299.00**

Art.-No. 1156X2 R220 £ **2,479.00**

REMS V-Jet TW

disinfection unit for drinking water installations, for feeding dosing solution for disinfection

Art.-No. 115602 R

£ **216.00**

REMS Peroxi Color

1 l bottle of REMS Peroxi dosing solution for disinfection of approx. 100 l line volume, 20 ml bottle of red REMS Color dye for dyeing the dosing solution for filling and wash-out check, pipette for checking the effectiveness of the dosing solution.

Art.-No. 115605 R

£ **63.80**

REMS V-Jet H

cleaning and preservation unit for heating systems, for feeding cleaner and corrosion protection.

Art.-No. 115612 R

£ **216.00**

REMS CleanH

1 l bottle of cleaner for heating systems, dyed green for filling and wash-out check, for approx. 100 l line volume.

Art.-No. 115607 R

£ **43.80**

REMS NoCor

1 l bottle of corrosion protection for preservation of heating systems, dyed blue for filling check, for approx. 100 l line volume.

Art.-No. 115608 R

£ **47.30**

Patent EP 2 816 231 pending!

Patent EP 2 954 960 pending!



SLW Set

German quality product

With colour coding system!

The active ingredients for disinfection, cleaning and preservation have different colours. The colouring enables you to monitor whether the active ingredients are added completely or washed out again.

Starter-Set TW-H for disinfection, cleaning and preservation



Peroxi

CleanH

NoCor



Printer

for printing the stored results of the flushing and test programs

Art.-No. 115604 R

£ **329.00**

¹⁾ Leak testing of drinking water installations with compressed air in accordance with information leaflet "Leak Testing of Drinking Water Installations" (January 2011) of the German Central Association for Sanitary, Heating and Air Conditioning (ZVSHK). Disinfection of drinking water installations in accordance with EN 806-4:2010 and information leaflet "Flushing, Disinfection and Commissioning of Drinking Water Installations" (August 2014) of the German Central Association for Sanitary, Heating and Air Conditioning (ZVSHK).

²⁾ Leak test of gas installation with compressed air in accordance with technical rules "DVGW-TRGI 2008, Technical Rules for Gas Installations – DVGW Work Sheet G 600" of the DVGW German Association of the Gas and Water Trade, Germany Leak test of gas installation with compressed air in accordance with technical rules "DVGW-TRGI 2008, Technical Rules for Gas Installations – DVGW Work Sheet G 600" of the DVGW German Association of the Gas and Water Trade, Germany

REMS Solar-Push – filling, flushing and venting in one action. Self priming. High displacement. Ideal for solar power systems, ground heat systems and underfloor heating.

Easy cleaning and simple filling thanks to large opening in the plastic container.

Two practical handles for easy carrying of the plastic container.

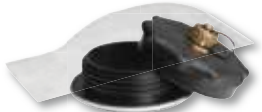

German quality product



REMS Solar-Push K 60

Transport volume ≤ 36 l/min, tank volume 30 l. With centrifugal pump, temperature-resistant for continuous load ≤ 60°C. Transport pressure ≤ 0.55 MPa/5.5 bar/80 psi. Condenser motor 230 V / 110 V, 50 Hz, 860 W. 2 pieces flexible, transparent PVC fabric hoses ½" T60, each 3 m long, temperature-resistant ≤ 60°C. In a carton.
Art.-No. 115312 R220 £ 720.00

£ **527.00**

REMS Solar-Push I 80

Electric filling and flushing unit for easy and fast filling, flushing and venting of closed systems. Pumping capacity ≤ 27 litres/min, tank volume 30 litres. With impeller pump, temperature resistant during constant use ≤ 80°C. Pumping pressure ≤ 0.65 MPa/6.5 bar/94 psi. Capacitor motor 230 V, 50 Hz, 1000 W. Pressure release valve. 2 flexible EPDM-fabric hoses ½" T100, 3 m long, high temperature resistant ≤ 100°C. In a carton.
Art.-No. 115311 R220 £ 800.00

£ **615.00**



Fine filter with fine filter bag 70 µm

consisting of screw cap with return connection for return line with ¾" union, adapter, 1 fine filter bag 70 µm, for flushing underfloor heating/wall radiators and clearing sludge
Art.-No. 115320

£ **77.20**

Fine filter with fine filter cartridge 90 µm

washable, with large dirt collection vessel, for return line with ¾" union, for flushing underfloor heating/wall radiators and clearing sludge
Art.-No. 115323 R

£ **162.00**

Changeover valve flow direction

complete with EPDM fabric hose ½" T100, for flushing underfloor heating/wall radiators and effective clearance of sludge by pressure surges when flow direction changes

Art.-No. 115326 R

£ **215.00**

REMS Pull-Push – fast removal of blockages.

High downforce thanks to front adjustable grip handle.

2 adaptor sleeves for optimum adaptation to the problem area: Short sleeve for sinks, basins and baths, long sleeve for toilets.



REMS Pull-Push

Manual suction / pressure pump for fast removal of blockages.

With short and long sleeves. In a carton.

Art.-No. 170300 R £ 105.00

£ **89.00**

REMS E-Push 2 – electrical filling and testing.

High-pressure hose with fabric inlay prevents falsification of the measuring result.

High-pressure reciprocating pump

High displacement of 6.5 l/min

Adjustable pressure limiting

Suction hose with suction filter



Up to 60 bar 1,300 W.
Self priming.

REMS E-Push 2

Electric pressure testing pump with pressure gauge for pressure and leak testing of pipe systems and tanks up to 6 MPa/60 bar/870 psi, with adjustable pressure limiting. Pump unit with condenser motor 110 V / 230 V, 50 Hz, 1,300 W. 1.5 m suction hose with ½" connection. 1.5 m high-pressure hose with ½" connection. Return trap. In a carton.

Art.-No. 115500 R220 £ 700.00

£ **529.00**

REMS Push – reliably tight.

Brass pressure piston



Tank volume 12 l
up to 60 bar

REMS Push

Manual pressure testing pump with pressure gauge, $p \leq 6 \text{ MPa}/60 \text{ bar}/870 \text{ psi}$, for pressure and leak testing of pipe systems and tanks up to $6 \text{ MPa}/60 \text{ bar}/870 \text{ psi}$. Corrosion-resistant, powder-coated sheet steel tank for 12 l. 1.5 m high-pressure hose with $\frac{1}{2}$ " connection. In a carton.

Art.-No. 115000 R £ 206.00

£ 147.⁰⁰



Stainless steel tank

REMS Push INOX

Manual pressure testing pump with pressure gauge, $p \leq 6 \text{ MPa}/60 \text{ bar}/870 \text{ psi}$, for pressure and leak testing of pipe systems and tanks up to $6 \text{ MPa}/60 \text{ bar}/870 \text{ psi}$. Stainless steel tank for 12 l. 1.5 m high-pressure hose with $\frac{1}{2}$ " connection. In a carton.

Art.-No. 115001 R £ 264.00

£ 205.⁰⁰

Split-second reversal of direction of spiral feed/return by fast switchover even under full load without changing the direction of rotation of the motor.

Patent EP 3 059 022



0–950 rpm
600 W, only 5.2 kg
German quality product

REMS Mini-Cobra S Set

Electric pipe cleaning device with fast switchover, for pipes $\varnothing 20\text{--}50$ (75) mm. For drain cleaning cables $\varnothing 8$ and 10 mm. Drive unit with maintenance-free gear, universal motor 230 V or 110 V, 50–60 Hz, 630 W, high-torque forward and reverse at low speed. Safety tip switch. Stepless, electronic speed control (acceleration switch) between 0 and 950 rpm. Cable drum in shock-proof, glass-fibre reinforced plastic. Cable $\varnothing 8$ mm, with core, 7.5 m long. In sturdy steel case

Art.-No. 170023 R220 £ 485.00

£ 359.⁰⁰

Proven, handy device for the fast unblocking of pipes, e.g. for kitchens, bathrooms and toilets.



German quality product



REMS Mini-Cobra

Pipe cleaning device for pipes $\varnothing 20\text{--}50$ (75) mm, with crank handle and hexagonal driver for conventional drive machine (electric, slow drilling machine with continuous drive or power drill/screwdriver). For pipe cleaning spirals $\varnothing 6$, 8 and 10 mm. Spiral drum made of impact-resistant, glass fibre-reinforced plastic. Quick-clamping chuck. Coil $\varnothing 8$ mm, 7.5 m long. In a carton.

Art.-No. 170010 R £ 148.00

£ 119.⁰⁰



German quality product

REMS Cobra 32 Set 22+32

Electric pipe and drain cleaning machine for pipes $\varnothing 20\text{--}250$ mm ($\frac{1}{4}\text{--}10$ ""). Drive unit with maintenance-free belt drive, capacitor motor 230 V, 50 Hz, 1050 W, right and left-hand rotation, guide hose. Personal protection switch (PRCD). 5 cable sections 22×4.5 m in cable carrier, straight auger 22, retrieving auger 22, funnel auger 22, toothed cross-blade borer 22/35, cable joint separator 22/32, 4 cable sections 32×4.5 m in cable carrier, straight auger 32, retrieving auger 32, funnel auger 32, toothed cross-blade borer 32/45, cable joint separator 22/32, 2 pairs of guide gloves, steel case/case for each tool set. In a carton.

Art.-No. 174011 R220 £ 3,270.00

£ 2,529.⁰⁰

REMS Cobra – Pipe free – quick and easy.

Fast rotator with spiral sections for working lengths up to 70 m. Effective chain spinning and cutting up to 740 rpm.

Closed drive spindle protects motor and drive against dirt and water.

REMS Cobra 22 Set 16+22

Electric pipe cleaning machine for pipes $\varnothing 20\text{--}150$ mm. Drive machine with maintenance-free toothed belt drive, 230 V, 50 Hz, 750 W condenser motor, right and left-hand rotation, guide hose. Personal protection switch (PRCD). 5 spiral sections 16×2.3 m in the spiral cage, straight drill 16, club drill 16, toothed blade drill 16/25, spiral cutting pin 16, 5 spiral sections 22×4.5 m in the spiral cage, straight drill 22, recovery drill 22, funnel drill 22, toothed cross blade drill 22/35, spiral cutting pin 22/32, 2 pairs of guide gloves, steel case for every tool kit. In a carton.

Art.-No. 172012 R220 £ 1,790.00

£ 1,219.⁰⁰

REMS RAS P – highly resistant pipe cutter for cutting plastic and multilayer composite tubes.

Very stable spindle, long spindle guide and specially hardened back pressure rollers. Exact guiding on the pipe, easy engagement, easy cutting and accurate, right-angled cut as a result. Quick adjustment of the engagement spindle in both directions.

International Design Award



REMS RAS P 10–40
Pipe cutter for pipes Ø 10–40 mm, ½–1½".
Art.-No. 290050 R £ 112.00

£ **91.00**

German quality product



REMS RAS P 50–110
Pipe cutter for pipes Ø 50–110 mm, 2–4"
Art.-No. 290100 R £ 173.00

£ **145.00**

German quality product



REMS RAS P 10–63
Pipe cutter for pipes Ø 10–63 mm, ½–2"
Art.-No. 290000 R £ 122.00

£ **103.00**



REMS RAS P 110–160
Pipe cutter for pipes Ø 110–160 mm, 4–6"
Art.-No. 290200 R £ 216.00

£ **178.00**

REMS ROS P – handy pipe cutter for clean, fast cutting of plastic and multilayer composite tubes.



REMS ROS P 26
Fast cutting in one cut.
Pipe shears for one-hand operation.
For pipes Ø ≤ 26 mm, 1".
Art.-No. 291240 R £ 42.10

£ **34.00**



REMS ROS P 35
Pipe cutter with fast return
for pipes Ø ≤ 35 mm, 1½".
Art.-No. 291200 R £ 45.70

£ **37.00**



Automatik

REMS ROS P 35 A
Pipe cutter with automatic
fast return for pipes Ø ≤ 35 mm, 1½".
Art.-No. 291220 £ 58.00

£ **47.00**



REMS ROS P 42
Pipe cutter with fast return
for pipes Ø ≤ 42 mm, 1½".
Art.-No. 291250 R £ 81.50

£ **65.00**



REMS ROS P 42 PS
Pipe cutter with fast return
for pipes Ø ≤ 42 mm, 1½".
Art.-No. 291000 RPS £ 61.70

£ **54.00**



REMS ROS P 42 S
Pipe cutter with fast return
for pipes Ø ≤ 42 mm, 1½".
Art.-No. 291010 R £ 72.00

£ **53.00**



REMS ROS P 63 P
Pipe cutter with fast return
for pipes Ø ≤ 63 mm, 2".
Art.-No. 291270 R £ 123.00

£ **99.00**



REMS ROS P 63 S
Pipe cutter with fast return
for pipes Ø ≤ 63 mm, 2".
Art.-No. 291290 R £ 133.00

£ **99.00**

REMS RAS Cu-INOX S – highly resistant, needle bearing mounted pipe cutter for cutting pipes made from stainless steel, carbon steel, copper etc. For very easy cutting.



Counter pressure rollers on needle bearings.
Cutting wheel on needle bearing.



Quick adjustment of the engagement spindle in both directions (REMS RAS Cu-INOX 8–64 S).



REMS RAS Cu-INOX 3–28S Mini
On needle bearing. For pipes
Ø 3–28 mm, ¼–1¼".
Art.-No. 113241 R £ 41.70

£ **35.00**



REMS RAS Cu-INOX 3–35S
On needle bearing with integrated pipe deburrer
for pipes Ø 3–35 mm, ¼–1¼".
Art.-No. 113351 R £ 60.30

£ **45.00**

International Design Award



German quality product

REMS RAS Cu-INOX 8–64S
On needle bearing with quick adjustment
for pipes Ø 8–64 mm, ¼–2½"
Art.-No. 113401 R £ 163.00

£ **117.00**

**REMS RAS St – Robust quality tools for cutting pipes.
Meets high demands and long service life.**



REMS RAS St 1/8–2"
Pipe cutter for pipes Ø 1/4–2", 10–60 mm.
Art.-No. 113000 R £ 156.00

£ **128.00**

Pipe cutter for steel pipes

German quality product



REMS RAS St 1 1/4–4"
Pipe cutter for pipes Ø 1 1/4–4", 30–115 mm.
Art.-No. 113100 R £ 312.00

£ **253.00**

REMS RAS Cu-INOX – highly resistant pipe cutter for cutting pipes made of stainless steel, carbon steel, copper etc.

Robust, sturdy structure for harsh conditions.
Very stable spindle, long spindle guide and specially hardened back pressure rollers.
Exact guiding on the pipe, easy engagement, easy cutting and accurate, right-angled cut as a result.



REMS RAS Cu-INOX 3–16
Pipe cutter for pipes Ø 3–16 mm, 1/8–3/4".
Art.-No. 113200 R £ 21.10

£ **19.00**



REMS RAS Cu-INOX 6–64
Pipe cutter for pipes Ø 6–64 mm, 1/4–2 1/2".
Art.-No. 113400 R £ 140.00

£ **112.00**

German quality product



REMS RAS Cu-INOX 3–28 Mini
Pipe cutter for pipes Ø 3–28 mm, 1/8–1 1/4".
Art.-No. 113240 R £ 31.40

£ **27.00**



REMS RAS Cu-INOX 3–28
Pipe cutter for pipes Ø 3–28 mm, 1/8–1 1/4".
Art.-No. 113300 R £ 24.60

£ **23.00**



REMS RAS Cu-INOX 3–35
Pipe cutter for pipes Ø 3–35 mm, 1/8–1 3/4",
with integrated pipe burr remover.
Art.-No. 113350 R £ 44.90

£ **37.00**

German quality product



REMS RAS Cu-INOX 6–42
Pipe cutter for pipes Ø 6–42 mm, 1/4–1 1/4".
Art.-No. 113380 R £ 117.00

£ **95.00**



REMS RAS Cu-INOX 3–42
Pipe cutter for pipes Ø 3–42 mm, 1/8–1 3/4",
with integrated pipe burr remover.
Art.-No. 113330 R £ 56.90

£ **44.00**

REMS RAS Cu – highly resistant pipe cutter especially for cutting copper pipes

Very stable spindle, long spindle guide and specially hardened back pressure rollers. Exact guiding on the pipe, easy engagement, easy cutting and accurate, right-angled cut as a result.



Quick adjustment of the engagement spindle in both directions.



REMS RAS Cu 8–42
Pipe cutter for pipes Ø 8–42 mm, 1/2–2 1/4".
Art.-No. 113370 R £ 105.00

£ **86.00**

German quality product



REMS RAS Cu 3–35
Pipe cutter for pipes Ø 3–42 mm, 1/8–1 3/4",
with integrated pipe burr remover.
Art.-No. 113340 R £ 41.40

£ **33.00**



REMS RAS Cu 8–64
Pipe cutter for pipes Ø 8–64 mm, 3/8–2 1/2".
Art.-No. 113410 R £ 130.00

£ **95.00**



REMS RAS Cu 3–42
Pipe cutter for pipes Ø 3–42 mm, 1/8–1 3/4",
with integrated pipe burr remover.
Art.-No. 113320 R £ 51.70

£ **39.00**

Rugged quality tools for tough use and long service life.



REMS Catch S 1" + S 1½" + W 240

Swedish pattern wrench 'S'. DIN 5234 – Form C. Water pump pliers, 7 grip positions. DIN ISO 8976. Art.-No. 116X01 R £ 112.00

£ **67.00**

Rugged design in chrome-vanadium steel, all steel, drop forged, tempered, powder-coated. Hardened, highly wear resistant toothing.



REMS Catch S 1" + S 1½" + S 2"

Swedish pattern wrench 'S'. DIN 5234 – Form C. Art.-No. 116X02 R £ 165.00

£ **95.00**

REMS Helix VE – drilling, screw driving and deburring.



LED work light



only 1.3 kg



FREE*

REMS Helix VE Li-Ion Set

Cordless power drill/screwdriver with Vario-Electronics (VE) for drilling in steel, stone, $\varnothing \leq 10$ mm, wood $\varnothing \leq 28$ mm and other materials and for screwing in/loosening screws $\varnothing \leq 7$ mm. Drive machine with keyless quick chuck, clamping range 0.8–10 mm, right and left hand rotation. Electromechanical drive with powerful battery motor 14.4 V, 300 W, 2-step robust planetary gear. 2 continuously ad-justable speed ranges from 0 to 300 rpm and 0 to 1,250 rpm, 25 torque stages plus drilling stage, high torque of 31 Nm in the low speed range. Safety switch. Integrated LED work light. Belt clip. Li-Ion 14.4 V, 1.5 Ah battery, Li-Ion/Ni-Cd 230 V, 50–60 Hz, 65 W rapid charger. 1 bit with double blade slot/cross-head, 50 mm long. In carrying bag. Art.-No. 190010 R220 £ 370.00

+ gift package with a value of £ 218.10

1 set of bits free

A second 14.4 V, 3.0 Ah Li-Ion battery free

1 bodywarmer XL

Art.-No. 190X02 R220 £ **355.00**



REMS tile drilling Set 6-8-10

Diamond-tipped dry drilling crowns with special wax filling. For ceramics, fine clay, granite, marble and other materials. 3 tile drill bits \varnothing 6, 8, 10 mm, drilling aid with vacuum attachment. For electric drive by power drill/screwdriver. Art.-No. 181700 R £ 170.00



£ **119.00**

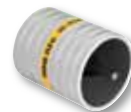

REMS REG 10–54 E

Outside/inside pipe deburrer for pipes \varnothing 10–54 mm, \varnothing ½–2 ¼".

For electric drive by power drill/screwdriver.

Art.-No. 113835 R £ 103.00

Patent EP 2 058 067

£ **82.00**



Driver for REMS REG 10–42

for electric drive by power drill/screwdriver.

Art.-No. 113815 R

£ **38.20**



REMS REG 10–42

Outside/inside pipe deburrer for pipes \varnothing 10–42 mm, \varnothing ½–1 ¾".

Art.-No. 113810 R

£ **89.60**

German quality product



REMS Swing – Bend pipes where they are laid, up to Ø 32 mm.

Ultra fast operation by practical multifunction lever for fast in-feed and fast return. Hardened steel rack.

REMS Swing Set 16-20-25/26-32

Soft copper pipes Ø 10–22mm, Ø ¼–¾", s ≤ 1mm, soft, coated copper pipes Ø 10–18mm, Ø ¼–¾", s ≤ 1mm, soft, coated carbon steel pipes of the pressfitting systems Ø 12–18mm, s ≤ 1.2mm, soft precision steel pipes Ø 10–18mm, s ≤ 1mm, composite tubes Ø 14–32mm. Up to Ø 26mm with drive unit, bending formers, back former supports S Ø 10–26mm with back formers, in a sturdy steel box/case. Up to Ø 32mm with drive unit, bending formers, 2 back former supports Ø 10–26mm and Ø 32mm with back formers, in a sturdy steel case. Art.-No. 153029 R £ 438.00

£ **309.00**

REMS Hydro-Swing – Effortless working due to oil-hydraulic force transmission. Ideal for composite tubes up to Ø 32 mm.

Also for stainless steel pipes up to Ø 22 mm.



German quality product

REMS Hydro-Swing

Oil-hydraulic hand pipe bender Ø 10–32mm, Ø ¼–¾", up to 90°. Soft copper pipes Ø 10–22mm, Ø ¼–¾", s ≤ 1mm, soft, coated copper pipes Ø 10–18mm, Ø ¼–¾", s ≤ 1mm, pipes of the press fitting systems made of stainless, nickel steel Ø 12–22mm, s ≤ 1.2mm, soft, coated carbon steel Ø 12–18mm, s ≤ 1.2mm, soft precision steel pipes Ø 10–22mm, s ≤ 1.5mm, composite tubes Ø 14–32mm. Up to Ø 26mm with drive unit, bending formers, back former support H-S Ø 10–26mm with back formers, Allen key, in a sturdy steel case. Up to Ø 32mm with drive unit, bending formers, 2 back former supports Ø 10–26mm and Ø 32mm with back formers, Allen key, in a sturdy steel case.

Soft copper pipes, pipes for press fitting systems made of stainless steel, etc.

Set 12-15-18-22

Art.-No. 153525 R £ 540.00

£ **399.00**

Composite tubes etc.

Set Set 16-20-25/26-32

Art.-No. 153529 R £ 580.00

£ **425.00**



German quality product



Tripod (accessory)

REMS Python – save expensive fittings. Super easy bending up to Ø 2", Ø 75 mm.

REMS Python

Oil-hydraulic pipe bender for dimensionally accurate bending of pipes up to 90°. Steel pipes EN 10225 Ø ¾–2", multilayer composite tubes Ø 32–75 mm. Drive unit with back former supports, upper back former support with laterally adjustable back former support bearing plate, 2 back formers, bending formers St or V. In sturdy transport case.

Steel pipes

Set St ¾ - 1½ - ¾ - 1 - 1¼"

Art.-No. 590020 R £ 1,240.00

£ **959.00**

Steel pipes

Set St ½ - ¾ - 1 - 1¼ - 1½ - 2"

Art.-No. 590021 R £ 1,360.00

£ **1,029.00**

Multilayer composite tubes

Set V 40 - 50 - 63mm

Art.-No. 590022 R £ 1,260.00

£ **969.00**

Tripod

Art.-No. 590150 R

£ **124.00**

Bending former and back formers 75 mm

Art.-No. 590063 R

£ **520.00**

German quality product



REMS Sinus

Universal for many tubes. Easy bending through long lever arms. Selectable lever positioning ensures optimum bending position and power transmission. Only one type of bending and back formers for REMS Sinus and REMS Curvo.

REMS Sinus Basic-Pack

Hand tube bender Ø 10–32 mm, Ø ¼–¾", up to 180°. Hard, half-hard, soft copper tubes, also thin-wall Ø 10–22 mm, Ø ¼–¾", coated soft copper tubes, also thin-wall Ø 10–18 mm, pipes of the press fitting systems made of stainless steel, carbon steel (coated) Ø 12–18 mm, soft precision steel tubes Ø 10–22 mm, soft precision steel tubes, Ø 10–20 mm, electric conduit EN 50086, Ø 16–20 mm, multi-layer composite tubes Ø 14–32 mm and others. Drive unit, insert bolt. Bending and back formers not included. See list in table. REMS bending spray. In sturdy steel case.
Art.-No. 154010 R £ 370.00

£ **319.00**

REMS Curvo – Bending pipes up to Ø 40 mm, 180°.

Bending instead of expensive fittings! The cost of REMS Curvo is recovered just after a few bends. Without vice. Ready to use immediately without setting.



1000 W – only 8 kg

German quality product

REMS Curvo Basic-Pack

Electric pipe and tube bender Ø 10–40 mm, Ø ¼–1½", up to 180°. Hard, semi-hard, soft copper pipes, also thin-walled, Ø 10–35 mm, Ø ¼–1½", soft coated copper pipes, also thin-walled, Ø 10–18 mm, thick-walled copper pipes K65 for refrigeration and air conditioning technology EN 12735-1 Ø ¼–1½", pipes of the press fitting systems of stainless steel Ø 12–28 mm, carbon steel, also coated, Ø 12–28 mm, soft precision steel pipes Ø 10–28 mm, steel pipes EN 10255 Ø ¼–¾", electrical installation pipes EN 50086 Ø 16–32 mm, composite tubes Ø 14–40 mm, etc. Drive unit with maintenance-free gear and safety slipping clutch, universal motor 230 V or 110 V, 50–60 Hz, 1000 W, stepless electronic safety switch, right and left-hand rotation, insert bolt. Bending formers and back formers¹⁾. In sturdy steel case.
Art.-No. 580010 R220 £ 1,060.00

£ **765.00**



3B

Machine support 3B

height adjustable, on tripod
Art.-No. 586100 R

£ **180.00**

¹⁾For bending formers and back formers with the respective smaller radius, see the table on the right.

One system – 4 applications!

Ideal for plumbers!

Speed-Regulation (Patent EP 2 085 191)

The electronic speed control that is being used keeps the selected speed constant, also under load.



REMS Picus SR Set Titan

Electric diamond core drilling machine with speed regulation. For core drilling in concrete, steel-reinforced concrete up to $\leq \varnothing 162$ (200) mm, masonry and other materials up to $\leq \varnothing 250$ mm. For dry or wet drilling, hand held or with drill stand. Drive machine with drilling crown connection thread UNC 1¼ male, G ½ female, maintenance-free 2-step gear with safety slip clutch, 110 V, 50–60 Hz, 2200 W universal motor. Stepless electronic speed regulation 200 rpm to 500 rpm (1st gear) or 500 rpm to 1200 rpm (2nd gear), overheating protection. Multifunction electronics with soft starting, idle speed limiting, overload protection, blocking protection. Touch switch with lock. Personal protection switch (PRCD). Water supply device with adjustable shut-off valve and quick coupling with water stop and ½" hose connection. Stabiliser. Spacer set. Single open ended wrench size 32. In sturdy steel case. Drill stand REMS Titan including fastening kit for masonry and concrete. Without diamond core drilling crowns.

Art.-No. 183022 R220 £ 2,270.00

£ **1,719.00**

REMS Picus SR Set 62-82-132 Titan

Same as Art.-No. 183022, but with REMS Universal diamond core drilling crowns UDKB $\varnothing 62, 82, 132$ mm.

Art.-No. 183023 R220 £ 2,680.00

£ **2,159.00**

... now with REMS Titan drill stand – for highest demands. For core drilling up to $\varnothing 300$ mm.

REMS Picus S2/3.5 – for core drillings in steel-reinforced concrete etc. up to $\varnothing 300$ mm.



REMS Picus S2/3,5 Set Titan

Electric diamond core drilling machine for core drilling in concrete, steel-reinforced concrete, all kinds of masonry, natural stone, asphalt, all kinds of screed, $\varnothing 40-300$ mm. For dry or wet drilling with drill stand. Drive machine with drilling crown male connection thread UNC 1¼, maintenance-free 2-step gear with safety slip clutch, 110 V, 50–60 Hz, 3420 W universal motor. Multifunction electronics with soft starting, idle speed limiting, overload protection, blocking protection. Rocker switch. Personal protection switch (PRCD). Load speed drilling spindle 320 rpm, 760 rpm. Water supply device with adjustable shutoff valve and quick coupling with water stop and ½" hose connection. Easy loosening ring. Single open-ended wrench size 32. Drill stand REMS Titan including fastening kit for masonry and concrete. Without diamond core drilling crowns. In a box.

Art.-No. 180030 R220 £ 4,030.00

£ **3,119.00**

REMS Picus S1 – the low cost alternative



... now with REMS Simplex 2 drill stand

Robust, handy drill stand for core drilling up to $\varnothing 200$ mm. Drill column made of rigid, unbendable square precision steel tube $\varnothing 50$ mm, cold solidified, with extra narrow tolerance, for low-vibration guiding of the slide

REMS Picus S1 Basic-Pack

Electric diamond core drilling machine for core drilling in concrete, steel-reinforced concrete up to $\leq \varnothing 102$ (132) mm, masonry and other materials up to $\leq \varnothing 162$ mm. For dry or wet drilling, hand held or with drill stand. Drive unit with drilling crown male connection thread UNC 1¼, female connection thread G ½, maintenance-free gear with safety slip clutch, 110 V / 230 V, 50 – 60 Hz, 1850 W universal motor. Multifunction electronics with soft starting, idle speed limiting, overload protection, blocking protection. Touch switch with lock Personal protection switch (PRCD). Load speed drilling spindle 580 rpm. Water supply device with adjustable shutoff valve and quick coupling with water stop and ½" hose connection. Stabiliser. Drill start aid G ½ with $\varnothing 8$ mm drill, size 3 Allen key. Size 32 opened ended wrench. In sturdy steel case.

Art.-No. 180010 R220 £ 1,340.00

£ **825.00**

REMS Picus S1 Set Simplex 2

Same as Art.-No. 180010, but with REMS Simplex 2 drill stand including fastening set for masonry and concrete. Without diamond core drilling crowns.

Art.-No. 180032 R220 £ 2,070.00

£ **1,449.00**



The low price Starter Set.
Ideal for pipework installers.

REMS UDKB Set 62-82-132

Ø 62, 82, 132 mm
Art.-No. 181102 R £ 590.00

£ **384.⁰⁰**

REMS UDKB LS Set 62-82-132

Ø 62, 82, 132 mm
Art.-No. 181112 R £ 590.00

£ **423.⁰⁰**

REMS Universal diamond core drilling crowns

Inductively soldered on fully automatic soldering machines for constant high quality of the soldered connection. Drilling tubes with soldered diamond segments can be resoldered by simple hard soldering.

Universally usable for many materials, for dry and wet drilling, hand held or with drill stand. Uniform UNC 1/4 female connection thread. Drilling depth 420 mm. Diamond segments with wedge-shaped cut ("roof shape") for fast, easy and quiet drilling. Specially developed, high quality diamond segments with high diamond content and special bonding for excellent drilling performance and very long life. Ideal for universal use in steel-reinforced concrete and masonry.

Can be driven by all REMS Picus drive units and suitable drive units of other makes with a UNC 1/4 male connection thread.

**Inductively soldered!
Resolderable!**



-35%

German quality product



Ø × drilling depth × connection		Art.-No.	£	Offer £
UDKB 32 × 420 × UNC 1/4	4	181010 R	110.00	72.00
UDKB 42 × 420 × UNC 1/4	4	181015 R	116.00	75.00
UDKB 52 × 420 × UNC 1/4	5	181020 R	129.00	84.00
UDKB 62 × 420 × UNC 1/4	6	181025 R	146.00	95.00
UDKB 72 × 420 × UNC 1/4	7	181030 R	160.00	104.00
UDKB 82 × 420 × UNC 1/4	7	181035 R	164.00	107.00
UDKB 92 × 420 × UNC 1/4	8	181040 R	183.00	119.00
UDKB 102 × 420 × UNC 1/4	8	181045 R	188.00	122.00
UDKB 112 × 420 × UNC 1/4	9	181050 R	209.00	136.00
UDKB 125 × 420 × UNC 1/4	10	181057 R	252.00	164.00
UDKB 132 × 420 × UNC 1/4	11	181060 R	248.00	161.00
UDKB 152 × 420 × UNC 1/4	12	181065 R	290.00	189.00
UDKB 162 × 420 × UNC 1/4	12	181070 R	296.00	192.00
UDKB 182 × 420 × UNC 1/4	12	181075 R	317.00	206.00
UDKB 200 × 420 × UNC 1/4	12	181080 R	328.00	213.00
UDKB 225 × 420 × UNC 1/4	13	181085 R	473.00	307.00
UDKB 250 × 420 × UNC 1/4	14	181090 R	498.00	324.00
UDKB 300 × 420 × UNC 1/4	22	181095 R	540.00	351.00

REMS universal diamond core drilling crowns LS (LASER)

Laser-welded on fully automatic welding machines for consistent high quality of the weld. High temperature-resistant, even under extreme temperature load, no desoldering of the segments due to overheating.

Universally usable for many materials, for dry and wet drilling, hand held or with drill stand. Uniform UNC 1/4 female connection thread. Drilling depth 420 mm. Diamond segments with wedge-shaped cut ("roof shape") for fast, easy and quiet drilling. Specially developed, high quality diamond segments with high diamond content and special bonding for excellent drilling performance and very long life. Ideal for universal use in steel-reinforced concrete and masonry.

Can be driven by all REMS Picus drive units and suitable drive units of other makes with a UNC 1/4 male connection thread.

**Laser-welded!
High temperature-resistant!**



-35%



Ø × drilling depth × connection		Art.-No.	£	Offer £
UDKB LS 32 × 420 × UNC 1/4	1	181410 R	144.00	94.00
UDKB LS 42 × 420 × UNC 1/4	4	181415 R	127.00	83.00
UDKB LS 52 × 420 × UNC 1/4	5	181420 R	142.00	92.00
UDKB LS 62 × 420 × UNC 1/4	6	181425 R	161.00	105.00
UDKB LS 72 × 420 × UNC 1/4	6	181430 R	177.00	115.00
UDKB LS 82 × 420 × UNC 1/4	7	181435 R	181.00	118.00
UDKB LS 92 × 420 × UNC 1/4	8	181440 R	201.00	131.00
UDKB LS 102 × 420 × UNC 1/4	9	181445 R	208.00	135.00
UDKB LS 112 × 420 × UNC 1/4	9	181450 R	231.00	150.00
UDKB LS 125 × 420 × UNC 1/4	10	181457 R	278.00	181.00
UDKB LS 132 × 420 × UNC 1/4	10	181460 R	272.00	177.00
UDKB LS 152 × 420 × UNC 1/4	11	181465 R	319.00	207.00
UDKB LS 162 × 420 × UNC 1/4	12	181470 R	327.00	213.00
UDKB LS 182 × 420 × UNC 1/4	13	181475 R	381.00	248.00
UDKB LS 200 × 420 × UNC 1/4	14	181480 R	394.00	256.00

REMS Pull – for dry and wet suction.

Constantly high suction performance by permanent automatic filter cleaning. Certified for collecting health hazardous dusts in accordance with EN 60335-2-69¹⁾.

REMS Pull

Electric dry and wet industrial vacuum cleaner / dust extractor. For extraction of dusts, dirt and liquids. Ideal for dust extracting when chasing, cutting, drilling, core drilling and grinding. Bypass motor 230 V, 50–60 Hz, 1,200 W. On/Off switch and switch for automatic filter cleaning with integrated green LED. Suction power switch for continuous adjustment of the air volume flow ≤ 74 l/s. Filling level limit with automatic switch-off. Automatic filter cleaning. Appliance socket for power tools up to 2,200 W, with electronic automatic on/off. Large tank capacity 35 l, filling volume for liquids 19 l. Mobile, 2 wheels, steering roller/steering roller with brake. Connecting cable 7.5 m. 1 paper filter bag, 1 flat folded paper filter. 2 suction hoses 0.5 m, handle piece, suction hose 2.5 m, suction hose extension 2.5 m, handle, 2 metal suction pipes 0.5 m each. Attachment for surfaces wet/dry 300 mm with rollers, brush strips, rubber lips. Attachment for joints. Adapter suction hose/power tool. Integrated holders for connecting cable, suction hose and accessories. In a box.

REMS Pull L Set

Certified as an industrial vacuum cleaner and dust extractor for collecting health hazardous dusts of dust class L¹⁾. Exposure limit/work place limit > 1 mg/m³, penetration level ≤ 1 %.

Art.-No. 185500 R220 £ 590.00

£ **499.00**

REMS Pull L Set W

REMS Pull L Set W – ideal for the removal of drilling mud during wet drilling with REMS drill stands. REMS Pull L Set with water-resistant flat-folded paper filter PES and water suction device.

Art.-No. 185503 R220 £ 970.00

£ **799.00**

REMS Pull M Set

Certified as an industrial vacuum cleaner and dust extractor for collecting health hazardous dusts of dust class M¹⁾. Exposure limit/work place limit > 0.1 mg/m³, penetration level ≤ 0.1 %. With antistatic system. Electrically conductive suction hose E. Electronic volume flow monitor, selector switch suction hose diameter, plug for the suction hose connecting nozzle.

REMS Pull M with antistatic system: static charge is discharged via the earthed upper section of the vacuum cleaner by electrically conductive metal suction hoses, handle piece E, electrically conductive suction hose E, electrically conductive suction hose extension E and electrically conductive suction hose connecting nozzles.

Art.-No. 185501 R220 £ 830.00

£ **649.00**

REMS Pull M Set D

REMS Pull M Set D – ideal for the extraction of hazardous dust when dry drilling with REMS Picus S1, Picus SR, Picus S3, amongst others. REMS Pull M Set with suction rotor for dust extraction.

Art.-No. 185504 R220 £ 940.00

£ **759.00**



REMS Contact 2000 – the smallest, strongest and fastest unit of its kind.



Operating power = soldering power = 2,000 W!
Therefore soldering time e.g. for \varnothing 18 mm only 18 s.

REMS Contact 2000 Super-Pack

Electric soldering unit for soft soldering of copper tubes \varnothing 6–54 mm, \varnothing 1/4–2 1/4". 230 V or 110 V, 50–60 Hz, 2000 W, control voltage 24 V. Soldering pliers with 4 m cable length, safety transformer, 4 prism electrodes, 2 rod electrodes, 250 g quality soft solder REMS Lot Cu 3, 250 g quality soft solder paste REMS Paste Cu 3, 1 tubing cutter REMS RAS Cu-INOX 3-35, pack of 10 cleaning pads REMS Cu-Vlies. In sturdy steel case.

Art.-No. 164050 R220 £ 750.00

£ **639.00**



Extraction of health hazardous dusts in accordance with EN 60335-2-69

When working with mineral building materials, e.g. concrete, steel-reinforced concrete, masonry and screed, a high degree of mineral dust containing quartz is produced which is harmful to the health. Inhalation of quartz fine dust is harmful to the health. EN 60335-2-69 prescribes the use of at least one safety extractor of dust class M¹⁾ for the extraction of health hazardous dusts with an exposure limit/work place limit of > 0.1 mg/m³. REMS Pull M, wet and dry industrial vacuum cleaner, certified for extracting hazardous dust of dust class M, see left.

REMS Krokodil – chasing instead of chiselling.

Full contact support plate during the entire chasing/cutting process for guided plunge-in of the diamond cutting discs, dust-free, safe working and easy, even feed.



Speed-Regulation (Patent EP 2 085 191)

The electronic speed control that is being used keeps the selected speed constant, also under load.



REMS Krokodil 180 SR



REMS Krokodil 125 + REMS Pull M



German quality product



FREE*

+ gift package with a value £ 164.60*

2 REMS universal diamond cutting disc LS H-P Ø 180 mm



FREE*

+ gift package with a value £ 52.80*

2 REMS universal diamond cutting disc LS-Turbo Ø 125 mm

REMS Krokodil 180 SR Basic-Pack

Electric diamond chasing and cutting grinder with speed regulation. For chasing and cutting, e.g. concrete, steel-reinforced concrete, masonry of all kinds, natural stone, screeds of all kinds. Chase depth ≤ 61 mm, continuously adjustable. Chasing width ≤ 62 mm, stepped with spacer discs 3, 6, 10, 20 mm. Drive machine with drive shaft Ø 22.2 mm, for 1, 2 or 3 diamond cutting discs in accordance with EN 13236, ≤ Ø 180 mm, with maintenance-free gear, 110 V, 50–60 Hz, 2,000 W universal motor. Multifunction electronics with soft start, idling speed limiting, overload protection. Overheating protection. Connecting cable 5.7 m. Restart protection in case of mains failure. Safety switch with lock. Load speed 4,500 rpm. Suction nozzle for connecting a vacuum cleaner/dust extractor (e.g. REMS Pull M). Pin wrench size 13. In sturdy steel case.

Art.-No. 185011 R220 £ 960.00

Art.-No. 185X03 R220 £ **819.00**



REMS universal diamond cutting disc LS-Turbo Ø 180 mm

Laser-welded, high temperature-resistant, for fast cuts and cuts in hard materials, with metal body in accordance with EN 13236

Art.-No. 185026 R

£ **48.70**



REMS universal diamond cutting disc LS H-P Ø 180 mm

High-performance, laser-welded, high temperature-resistant, for fast cuts and cuts in very hard materials, long life, with metal body in accordance with EN 13236.

Art.-No. 185027 R

£ **82.30**

REMS Krokodil 125 Basic-Pack

Electric diamond chasing and cutting grinder for chasing and cutting, e.g. concrete, steel-reinforced concrete, masonry of all kinds, natural stone, screeds of all kinds. Chase depth ≤ 38 mm, continuously adjustable. Chasing width ≤ 43 mm, stepped with spacer discs 3, 6, 10, 20 mm. Drive machine with drive shaft Ø 22.2 mm, for 1 or 2 diamond cutting discs in accordance with EN 13236, ≤ Ø 125 mm, with maintenance-free gear with safety slip clutch, 110 V, 50–60 Hz, 1,850 W universal motor. Multifunction electronics with soft start, idling speed limiting, overload protection. Connecting cable 2.3 m. Safety switch with lock. Load speed 5,000 rpm. Suction nozzle for connecting a vacuum cleaner/dust extractor (e.g. REMS Pull M). Pin wrench size 13. In sturdy steel case.

Art.-No. 185010 R220 £ 930.00

Art.-No. 185X02 R220 £ **719.00**



REMS universal diamond cutting disc LS-Turbo Ø 125 mm

Laser-welded, high temperature-resistant, for fast cuts and cuts in hard materials, with metal body in accordance with EN 13236

Art.-No. 185021 R

£ **26.40**



REMS universal diamond cutting disc LS H-P Ø 125 mm

High-performance, laser-welded, high temperature-resistant, for fast cuts and cuts in very hard materials, long life, with metal body in accordance with EN 13236.

Art.-No. 185022 R

£ **52.90**

¹⁾ Observe the national regulations for the collection and disposal of health hazardous dusts.

REMS CamScope / REMS CamScope S – Brilliant pictures and videos of cavities, shafts and pipes. Documentation on MicroSD card.



REMS CamScope

Mobile, handy endoscope camera with radio signal transmission for low cost inspection and damage analysis of places with difficult access such as cavities, shafts, pipes etc. Documentation of photos and videos on MicroSD card. Handheld unit with 4 batteries 1.5 V, AA, LR6 Removable controller unit with radio signal transmission, 3.5" TFT-LCD colour display, 3x digital zoom, MicroSD card slot, USB port, video out socket PAL/NTSC, integrated Li-ion battery, 3.7 V, 1.2 Ah. 2 GB MicroSD card Voltage supply/charger Li-Ion 100–240 V, 50 – 60Hz, 9 W, for controller unit. USB cable, video cable in sturdy case Optional with camera cable set 4.5-1, camera cable set 9-1 or camera cable set 16-1.



REMS CamScope S – with voice recording.

Mobile, handy endoscope camera with radio signal transmission for low cost inspection and damage analysis of places with difficult access such as cavities, shafts, pipes etc. Documentation of photos and videos with voice recording on MicroSD card. Handheld unit with 4 batteries 1.5 V, AA, LR6 Removable controller unit with radio signal transmission, 3.5" TFT-LCD colour display, 3x digital zoom, MicroSD card slot, USB port, video out socket PAL/NTSC, integrated Li-ion battery, 3.7 V, 1.2 Ah. 2 GB MicroSD card Voltage supply/charger Li-Ion 100–240 V, 50 – 60Hz, 9 W, for controller unit. USB cable, video cable in sturdy case Optional with camera cable set 4.5-1, camera cable set 9-1 or camera cable set 16-1.

REMS CamScope Set 16-1

Camera cable set Color 16-1, consisting of colour camera Ø 16 mm, 704×576 pixels, with dimmable white light LEDs and fixed focus function and 1 m formable push cable. Add-on mirror, add-on hook, add-on magnet. Art.-No. 175110 R220 £ 378.00

£ **319.00**

REMS CamScope S Set 16-1

Camera cable set Color 16-1, consisting of colour camera Ø 16 mm, 704×576 pixels, with dimmable white light LEDs and fixed focus function and 1 m formable push cable. Add-on mirror, add-on hook, add-on magnet. Art.-No. 175130 R220 £ 469.00

£ **365.00**

REMS CamScope Set 9-1

Camera cable set Color 9-1, consisting of colour camera Ø 9 mm, 640×480 pixels, with dimmable white light LEDs and fixed focus function and 1 m formable push cable. Add-on mirror, add-on hook, add-on magnet. Art.-No. 175111 R220 £ 385.00

£ **325.00**

REMS CamScope S Set 9-1

Camera cable set Color 9-1, consisting of colour camera Ø 9 mm, 640×480 pixels, with dimmable white light LEDs and fixed focus function and 1 m formable push cable. Add-on mirror, add-on hook, add-on magnet. Art.-No. 175131 R220 £ 475.00

£ **375.00**

REMS CamScope Set 4,5-1

Camera cable set Color 4.5-1, consisting of colour camera Ø 4.5 mm, 320×240 pixels, with dimmable white light LEDs and fixed focus function and 1 m formable push cable. Ideal for inspecting small pipe bends and narrow places. Art.-No. 175112 R220 £ 444.00

£ **355.00**

REMS CamScope S Set 4,5-1

Camera cable set Color 4.5-1, consisting of colour camera Ø 4.5 mm, 320×240 pixels, with dimmable white light LEDs and fixed focus function and 1 m formable push cable. Ideal for inspecting small pipe bends and narrow places. Art.-No. 175132 R220 £ 540.00

£ **425.00**



900 mm push cable extension

couplable up to a working length of 4.5 m
Art.-No. 175105 R

£ **39.10**

Camera cable set Color 16-1 90°

90° angled colour camera Ø 16 mm, 640×480 pixels, with 1 m flexible push cable.
Art.-No. 175106 R

£ **131.00**

REMS CamSys – electronic camera inspection system for low-cost inspection and damage analysis.



REMS CamSys Set S-Color

Electronic camera inspection system for low-cost inspection and damage analysis. Documentation of pictures and videos on SD card with specification of date and time. Controller unit in microprocessor technology with 3.5" TFT-LCD colour display, SD card slot, USB port, video out socket PAL/NTSC, integrated Li-Polymer battery, 3.7 V, 4.0 Ah, in sturdy, impact-proof plastic housing, spray protected, glare protection, stand. 2 m connecting cable from the controller unit to the camera cable set, voltage supply/charger 100–240 V, 50–60 Hz, 15 W, SD card 4 GB, USB cable, in sturdy case. Camera cable set S-Color with high resolution special colour camera Ø 25 mm with CMOS image sensor and push cable.

REMS CamSys Set S-Color 10 K

10 m push cable Ø 4.5 mm with length mark, very flexible, in cable reel. For small pipe diameters and narrow pipe bends Ø (40) 50–150 mm, drains, shafts, stacks and other cavities. Art.-No. 175008 R220 £ 1,950.00

£ **1,499.00**



REMS CamSys Set S-Color 20 H

20 m push cable Ø 4.5 mm, very flexible, in hasp with electronic metre counter. For small pipe diameters and narrow pipe bends Ø (40) 50–150 mm, drains, shafts, stacks and other cavities. Art.-No. 175007 R220 £ 2,390.00

£ **1,929.00**



REMS CamSys Set S-Color 30 H

30 m push cable Ø 5.4 mm, flexible, in hasp with electronic metre counter. For pipes Ø 50–150 mm, drains, shafts, stacks and other cavities. Art.-No. 175010 R220 £ 2,420.00

£ **1,959.00**

REMS CamSys 2 – electronic camera inspection system for low-cost inspection and damage analysis. Voice recording. Self-levelling camera. Transmitter for localising camera heads.



REMS CamSys 2 Set S-Color – with voice recording.

Electronic camera inspection system for low-cost inspection and damage analysis. Documentation of pictures and videos with voice recording on SD card with specification of date and time. Controller unit in microprocessor technology with 7" TFT-LCD colour display, SD card slot, USB port, video out socket PAL/NTSC, integrated Li-Polymer battery 3.7 V, 7.6 Ah, in sturdy, impact-proof plastic housing, spray protected, glare protection, stand. 2 m connecting cable from the controller unit to the camera cable set, voltage supply/charger 100–240 V, 50–60 Hz, 15 W, SD card 4 GB, USB cable, video cable, in sturdy case. Camera cable set S-Color with high resolution special colour camera with CMOS image sensor and push cable.

REMS CamSys 2 Set S-Color 10 K

High resolution special colour camera Ø 25 mm, 10 m push cable Ø 4.5 mm with length mark, very flexible, in the cable reel. For small pipe diameters and narrow pipe bends Ø (40) 50–150 mm, drains, shafts, stacks and other cavities. Art.-No. 175301 R220 £ 2,470.00



£ **1,999.00**

REMS CamSys 2 Set S-Color 20 H

High resolution special colour camera Ø 25 mm, 20 m push cable Ø 4.5 mm, very flexible, in the hasp with electronic metering. For small pipe diameters and narrow pipe bends Ø (40) 50–150 mm, drains, shafts, stacks and other cavities. Art.-No. 175302 R220 £ 2,990.00



£ **2,419.00**

REMS CamSys 2 Set S-Color S 30 H

High resolution special colour camera Ø 25 mm, 33 kHz transmitter for localising the camera head, 30 m push cable Ø 5.4 mm, flexible, in the hasp with electronic metering. For pipes Ø 50–150 mm, drains, shafts, stacks and other cavities. Art.-No. 175303 R220 £ 3,200.00



£ **2,609.00**

REMS CamSys 2 Set S-Color S-N 30 H

High resolution special colour camera Ø 33 mm, self-levelling, 33 kHz transmitter for localising the camera head, 30 m push cable Ø 5.4 mm, flexible, in the hasp with electronic metering. For pipes Ø 70–150 mm, drains, shafts, stacks and other cavities. Art.-No. 175304 R220 £ 3,450.00

£ **2,759.00**

**REMS Puma VE – the powerful universal saw with anti-vibration system.
Quick saw blade change without tools.
Adjustable support shoe.**

Saw blade can be inserted turned 180°.



1300 W – 3.8 kg



REMS Puma VE Set

Electric universal reciprocating saw with Vario-Electronics (VE) for free hand sawing, with anti-vibration system. Drive machine with D-shaped handle with soft grip, maintenance-free oscillation drive, powerful 230 V, 50–60 Hz, 1,300 W universal motor, safety switch, connecting cable 4 m. Continuous electronic stroke speed control (accelerator switch) 0 to 2,800 rpm. 30 mm stroke. Saw blade holder with quick-change system. Adjustable support shoe. 1 REMS saw blade 210-1.8/2.5. In sturdy steel case.
Art.-No. 560023 R220 £ 296.00

£ **199.⁰⁰**

REMS saw blades for metal

→ REMS Puma, REMS Cat, REMS Akku-Cat, REMS Tiger, etc.



Designation	Length mm	Tooth pitch mm	Material*	Teeth	Quantity pieces	Art.-No.	List price £
REMS saw blade 150-1 sheet metal, metal, also stainless steel, ≥ 1.2 mm	150	1	HSS-Bi flexible	corrugated	5	561105 R05	19.40
REMS saw blade 200-1 sheet metal, metal, also stainless steel, ≥ 1.2 mm	200	1	HSS-Bi flexible	corrugated	5	561106 R05	25.10
REMS saw blade 90-1.4, curved blade metal, also stainless steel, ≥ 1.5 mm	90	1.4	HSS-Bi	corrugated	5	561107 R05	17.60
REMS saw blade 150-1.4 metal, also stainless steel, ≥ 1.5 mm	150	1.4	HSS-Bi flexible	corrugated	5	561104 R05	20.20
REMS saw blade 200-1.4 metal, also stainless steel, ≥ 1.5 mm	200	1.4	HSS-Bi flexible	corrugated	5	561108 R05	25.10
REMS saw blade 100-1.8 metal, also stainless steel, ≥ 2 mm	100	1.8	HSS-Bi flexible	corrugated	5	561101 R05	17.30
REMS saw blade 150-1.8 metal, also stainless steel, ≥ 2 mm	150	1.8	HSS-Bi flexible	corrugated	5	561103 R05	20.00
REMS saw blade 200-1.8 metal, also stainless steel, ≥ 2 mm	200	1.8	HSS-Bi flexible	corrugated	5	561102 R05	25.10
REMS saw blade 200-2.5 metal, also stainless steel, ≥ 3 mm	200	2.5	HSS-Bi flexible	straight-set	5	561109 R05	25.50
REMS saw blade 280-2.5 metal, also stainless steel, ≥ 3 mm	280	2.5	HSS-Bi flexible	straight-set	5	561112 R05	31.80

REMS saw blades for wood and metal

→ REMS Puma, REMS Cat, REMS Akku-Cat, REMS Tiger, etc.



Designation	Length mm	Tooth pitch mm	Material*	Teeth	Quantity pieces	Art.-No.	List price £
REMS saw blade 210-1.8/2.5 round tip, no sticking pallets, wood, wood with nails, metal ≥ 2.5 mm	210	Combo 1.8/2.5	HSS-Bi flexible	straight-set	5	561113 R05	25.80
REMS saw blade 150-2.5 wood, wood with nails, pallets, metal ≥ 3 mm	150	2.5	HSS-Bi flexible	straight-set	5	561110 R05	19.20
REMS saw blade 225-2.5 , extra thick, for disassembly wood, wood with nails, metal ≥ 3 mm	225	2.5	HSS-Bi	corrugated	3	561114 R03	24.90
REMS saw blade 300-2.5 , extra thick, for disassembly wood, wood with nails, metal ≥ 3 mm	300	2.5	HSS-Bi	corrugated	3	561116 R03	32.60
REMS saw blade 300-4.2 wood	300	4.2	WS	straight-set	5	561111 R05	23.50
REMS saw blade 225-3.2/5.0 wood, wood with nails	225	Combo 3.2/5.0	HSS-Bi flexible	straight-set	5	561117 R05	29.10
REMS saw blade 290-5.0/6.35 green wood	290	Combo 5.0/6.35	WS	straight-set	5	561118 R05	32.20
REMS saw blade 150-6.35 wood	150	6.35	WS	straight-set	5	561119 R05	13.60

REMS saw blades for different purposes

→ REMS Puma, REMS Cat, REMS Akku-Cat, REMS Tiger, etc.



Designation	Length mm	Tooth pitch mm	Material*	Teeth	Quantity pieces	Art.-No.	List price £
REMS saw blade 150-4.2 breeze blocks, plasterboard	150	4.2	WS	straight-set	5	561115 R05	16.70
REMS saw blade 225-8.5 breeze blocks, hard wood	225	8.5	HM	straight-set	1	561120 R01	43.60
REMS saw blade 300-8.5 breeze blocks, hard wood	300	8.5	HM	straight-set	1	561121 R01	52.00
REMS saw blade 400-8.5 breeze blocks, hard wood	400	8.5	HM	straight-set	1	561122 R01	74.40
REMS saw blade 235-12 breeze blocks, pumice, brick	235	12	HM	straight	1	561123 R01	60.20
REMS saw blade 300-12 breeze blocks, pumice, brick	300	12	HM	straight	1	561124 R01	69.80
REMS saw blade 300-12 , extra high blade breeze blocks, pumice, brick	300	12	HM	straight	1	561125 R01	83.00
REMS saw blade 200 cast iron etc.	200		HM-G		2	561126 R02	24.90

REMS special saw blades

→ REMS Tiger, etc.



REMS

Designation	Ø Zoll/ Length mm	Tooth pitch mm	Material*	Teeth	Quantity pieces	Art.-No.	List price £	Promotion price £
REMS special saw blade 2"/140-2.5 steel pipes ≤ 2"	2"/140	2.5	HSS-Bi	corrugated	5	561007 R05	46.60	31.90
REMS special saw blade 2"/140-3.2 steel pipes ≤ 2"	2"/140	3.2	HSS-Bi	corrugated	5	561001 R05	44.20	31.50
REMS special saw blade 4"/200-3.2 steel pipes ≤ 4"	4"/200	3.2	HSS-Bi	corrugated	5	561002 R05	58.80	38.00
REMS special saw blade 6"/260-3.2 steel pipes ≤ 6"	6"/260	3.2	HSS-Bi	corrugated	5	561008 R05	74.80	60.90

For materials that are difficult to cut, e.g. stainless steel pipes, hard cast iron pipes, instead of the REMS special saw blade the fine-toothed REMS universal saw blade in connection with REMS Tiger ANC SR with electronic stroke number regulation. *HSS-Bi: bimetal high speed steel

REMS universal saw blades

→ REMS Tiger, REMS Cat, REMS Akku-Cat, etc.



REMS

Designation	Length mm	Tooth pitch mm	Material*	Teeth	Quantity pieces	Art.-No.	List price £	Promotion price £
REMS universal saw blade 100-1.8/2.5 for all sawing work	100	Combo 1.8/2.5	HSS-Bi flexible	straight-set	5	561006 R05	29.80	23.00
REMS universal saw blade 150-1.8/2.5 for all sawing work	150	Combo 1.8/2.5	HSS-Bi flexible	straight-set	5	561005 R05	43.30	30.00
REMS universal saw blade 200-1.8/2.5 for all sawing work	200	Combo 1.8/2.5	HSS-Bi flexible	straight-set	5	561003 R05	57.60	39.40
REMS universal saw blade 300-1.8/2.5 for all sawing work	300	Combo 1.8/2.5	HSS-Bi flexible	straight-set	5	561004 R05	84.90	53.30

Also for wood with nails, pallets. For materials that are difficult to cut, e.g. stainless steel, hard cast iron, a low stroke number is necessary, e.g. by REMS Tiger ANC SR with electronic stroke number regulation. *HSS-Bi: bimetal high speed steel

REMS Cat ANC VE – saws everything anywhere. Extremely versatile and powerful. Robust and handy.



German quality product

1050 W – 3.0 kg

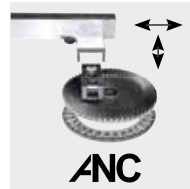

ANC – for maximum stress

REMS Cat ANC VE Set

Electric universal reciprocating saw with Vario Electronics (VE) for free-hand sawing. Drive unit with spade handle, maintenance-free, water and dust proof oscillation drive with all-round needle bearing crank drive (ANC), aggressive orbital stroke, powerful 110 V, 50–60 Hz, 1050 W universal motor, safety switch. Stepless electronic speed control (accelerator switch) 0–2400 rpm. Universal saw blade holder. Allen key. 1 REMS universal saw blade 150-1,8/2,5. In sturdy steel case. Art.-No. 560040 R220 £ 443.00

£ **319.00**

REMS Tiger ANC – the pipe reciprocating saw. Saws easily, fast and at right angles.

Fixed, optimum number of strokes especially for sawing steel pipes.



German quality product

1050 W – only 3 kg

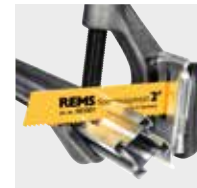
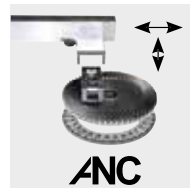

ANC – for maximum stress

REMS Tiger ANC Set

Electric pipe reciprocating saw for fast, easy, right-angled sawing with guide holder and for free-hand sawing. Drive unit with straight machine handle, maintenance-free, water and dust proof oscillation drive with all-round needle bearing crank drive (ANC), aggressive orbital stroke, powerful 110 V, 50–60 Hz, 1050 W universal motor, safety switch. Fixed number of strokes 2400 rpm. Overload protection. Universal saw blade holder. Allen key. Guide holder up to 2". 2 REMS special saw blades 2"/140-3,2. In sturdy steel case. Art.-No. 560020 R220 £ 560.00

£ **439.00**

REMS Tiger ANC SR – with Speed Regulation. Saws easily, quickly and at right angles.

Stepless electronic speed control. Also ideal for sawing stainless steel pipes. With speed generator.

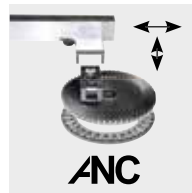

German quality product

1400 W – 3.1 kg

ANC – for maximum stress

REMS Tiger ANC SR Set

Electric pipe reciprocating saw with Speed Regulation (SR) for fast, easy, right-angled sawing with guide holder and for free-hand sawing. Drive unit with straight machine handle, maintenance-free, water and dust proof gear with all-round needle bearing crank drive (ANC), fixed orbital stroke, powerful 110 V, 50–60 Hz, 1400 W universal motor, safety switch. Stepless electronic speed control 700–2200 rpm with sensitive start-sawing, speed generator, temperature monitor and stall protection. Universal saw blade holder. Allen key. Guide holder up to 2". 2 REMS special saw blades 2"/140-3,2. In sturdy steel case. Art.-No. 560026 R220 £ 650.00

£ **505.00**

Guide holder for REMS Tiger etc.

Unique guide holder with five-fold force transmitting leverage allows effortless, fast, right angled sawing everywhere on site, without a vice. Ideal handling, very quick and easy operation, only one handle for clamping and sawing. In a box



Guide holder up to 4"

Guide holder 2½–4"
Art.-No. 563100 R £ 167.00

£ **114.00**

Guide holder up to 6"

Guide holder 5–6"
Art.-No. 563200 R £ 190.00

£ **114.00**

REMS Aquila 3B

Mobile pipe machining station. Safe clamping of pipes up to 6". Everywhere on site.

Ø 10–165 mm, ¼–6"



REMS Aquila 3B

Pipe processing station with chain pipe vice for clamping pipes Ø 10–165 mm, Ø ¼–6". Work plate with integrated chain pipe vice with double clamping jaws, pipe rest, tool holders, 3 benders for bending pipes Ø 10–26 mm, Ø ¼–¾", clamping head. Folding tripod stand with shelf plate. In a carton. Art.-No. 120270 R £ 391.00

£ **275.00**

REMS Aquila WB

Safe clamping of pipes up to 6".



Ø 10–165 mm, ¼–6"

German quality product

REMS Aquila WB

High quality chain pipe vice for clamping pipes Ø 10–165 mm, Ø ¼–6". Base plate with integrated chain pipe vice with double clamping jaws, pipe rest, bending device. For work bench. In a carton. Art.-No. 120250 R £ 243.00

£ **175.00**

Ideal for press fitting systems.



German quality product

REMS Turbo Cu-INOX – burr-reduced, right angle, rapid.

e.g. Ø 22 mm in only 4 s.

REMS Turbo Cu-INOX Basic

Circular pipe saw with universal double clamping vice for burr-reduced, right angle, rapid sawing. For stainless steel pipes, carbon steel pipes and copper pipes of the press fitting systems etc. Also for cutting thin-walled sections for front-wall installation. For REMS saw blade Ø 225 mm. With maintenance-free gear, proven universal motor 230 V or 110 V, 50–60 Hz, 500 W. Safety tip switch, saw blade protection cover. Speed 60 rpm. Ring spanner. Hexagon key. Without saw blade. For workbench, stand or wheel stand. In a carton.

Art.-No. 849006 R220 £ 980.00



+ gift package with a value £ 388.00*

1 REMS circular saw blade HSS-E (cobalt alloyed), 225 x 2 x 32, 220 teeth. Very long service life.
1 stand

Art.-No. 849X01 R220 £ **929.00**

For straight cuts and mitred cuts up to 45°.

With automatic coolant-lubricant device
German quality product



REMS Turbo K – burr-reduced, right angle, rapid.

e.g. 2" steel pipe in only 5 s.

REMS Turbo K Basic

Universal circular metal sawing machine with automatic cooling lubricant unit. For straight cuts and bevel cuts up to 45°. For REMS saw blade Ø 225 mm. Maintenance-free gear. Proven, powerful universal motor 230 V or 110 V, 50–60 Hz, 1200 W. Safety tip switch, saw blade protection cover, length stop. Clamp insert for thin-walled pipes. Speed 115 rpm. Ring spanner. Hexagon key. 1 filling of cooling lubricant REMS Spezial. Without saw blade.

For workbench, stand or wheel stand. In a carton.

Art.-No. 849007 R220 £ 1,200.00



+ gift package with a value £ 298.00

1 REMS circular saw blade HSS, 225 x 2 x 32, 120 teeth. Very long service life.
1 stand

Art.-No. 849X02 R110G £ **999.00**



Work plate 1100 x 700 x 26 mm
Working height 800 mm
Weight 28 kg
Load capacity ≤ 300 kg

Work plate 800 x 600 x 22 mm
Working height 800 mm
Weight 23 kg
Load capacity ≤ 300 kg

REMS Jumbo – assembled and disassembled at lightning speed.



REMS Jumbo

Folding workbench with toggle catch. Work plate in accordance with DIN 68 705. In a carton.

Art.-No. 120200 R £ 329.00

£ **199.00**

REMS Jumbo E

Folding workbench with toggle catch. Work plate in accordance with DIN 68 705. In a carton.

Art.-No. 120240 R £ 226.00

£ **159.00**

Ultra-fast, e.g. INOX Ø 54 mm in only 4 seconds.

Unique! Patent EP 1 782 904

Driven cutting wheel and straight in-feed for fast cutting

1200 W
Only 17 kg

German quality product

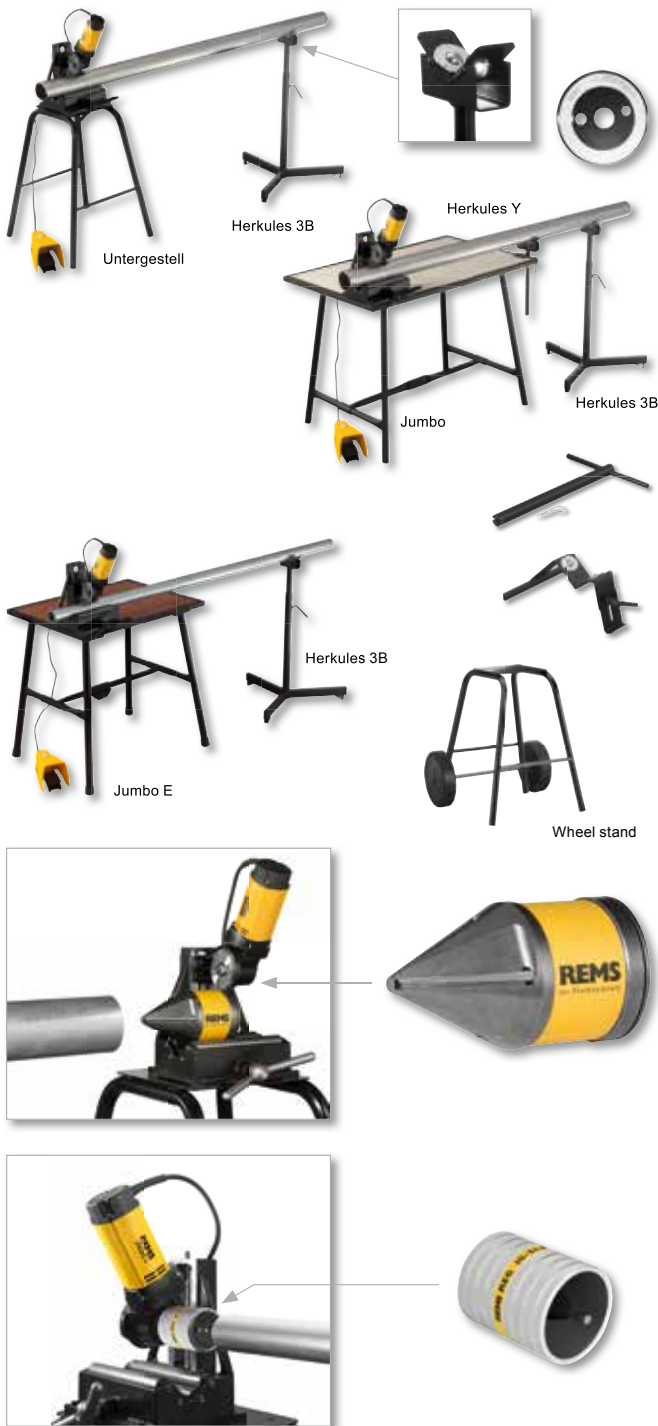

REMS Cento – Cutting and deburring up to Ø 115 mm.

Right-angled. Chipless. Without outer burr. Dry.

REMS Cento Basic

Pipe cutting machine for fast, right angled cutting of pipes Ø 8–115 mm, without outer burr. For pipes of the press fitting systems made from stainless steel, carbon steel, copper, Ø 8–108 mm. For steel pipes EN 10255 (DIN 2440) DN 10–100, Ø ¼–4", cast iron pipes (SML) EN 877 (DIN 19522) DN 50–100, plastic tubes SDR 11, wall thickness s ≤ 10 mm, Ø 10–110 mm, Ø ¼–4", composite tubes Ø 10–110 mm. With maintenance-free gear, proven 110 V, 50–60 Hz, 1200 W universal motor. Speed 115 rpm. Rollers made of hardened precision steel for pipes Ø 22–115 mm, Ø ¼–4". Safety foot switch. Ring spanner. Without cutting wheel. For work-bench, stand or wheel stand. In a carton. Art.-No. 845001 R220 £ 1,120.00



REMS cutting wheel Cu-INOX free!
Value £ 81.30

Art.-No. 845X02 R220 £ **919.00**

REMS cutting wheel Cu-INOX

for pipes of press fitting systems made of stainless steel, copper, carbon steel
Art.-No. 845050 R

£ **81.30**

REMS cutting wheel Cu

especially for pipes of the press fitting systems made of copper
Art.-No. 845053 R

£ **81.30**

REMS cutting wheel St

for steel pipes, cast pipes (SML)
Art.-No. 845052 R

£ **81.30**

REMS cutting wheel V, s 10

for plastic and multilayer composite tubes, wall thickness s ≤ 10 mm
Art.-No. 845051 R

£ **81.30**

REMS cutting wheel C-SF

for cutting carbon steel pipes and simultaneously producing a welding chamfer
Art.-No. 845055 R

£ **81.30**

REMS cutting wheel RF

for cutting longitudinally welded, EN 1124 stainless steel pipes (rainfall pipes) with REMS Cento RF.
Art.-No. 845054 R

£ **81.30**

Feed lever

for operating the drive unit on the floor
Art.-No. 845218 R

£ **67.20**

Pipe support 1

height adjustable, for pipes Ø 40–110 mm, Ø 1½–4", with operation of the drive unit with feed lever on the floor
Art.-No. 845220 R

£ **113.00**

Accessory Pack 1

consisting of stand and REMS Herkules 3B
Art.-No. 120X01 R £ 411.00

£ **300.00**

Accessory Pack 2

consisting of Jumbo, Herkules 3B and Herkules Y
Art.-No. 120X02 R £ 730.00

£ **499.00**

Accessory Pack 3

consisting of Jumbo E and Herkules 3B
Art.-No. 120X03 R £ 475.00

£ **344.00**

Accessory Pack 4

consisting of wheel stand and REMS Herkules 3B
Art.-No. 120X04 R £ 510.00

£ **390.00**

Inside pipe deburring device up to DN 100 – ideal for pipes of the pressfitting systems etc.

REMS REG 28–108

Inside pipe deburring device for pipes of Ø 28–108 mm, Ø ¾–4". For electric drive by the REMS Cento pipe cutting machine.
Art.-No. 113840 R £ 246.00

£ **209.00**

Patent EP 2 058 067

REMS REG 10–54 E – also for electric drive

Outer/inner pipe burr remover for pipes Ø 10–54 mm, ½–2½". Also for electric drive by REMS Helix (see page 10) and other power drills/screwdrivers (speed ≤ 300 rpm), by the pipe cutting machine REMS Cento (from date of manufacture 09/2011) or by the pipe circular sawing machine REMS Turbo Cu-INOX (from date of manufacture 09/2011).
Art.-No. 113835 R £ 103.00

£ **82.00**

Unique! Patent EP 1 782 904

Driven cutting wheel and straight in-feed for fast cutting

German quality product



REMS Cento RF – cutting of welded drain pipes /down pipes of stainless steel (EN 1124) Ø 40–110 mm.

REMS Cento RF Set

Pipe cutting machine especially for fast, right-angled cutting of longitudinally welded, EN 1124 stainless steel pipes (rainfall pipes) Ø 40–110 mm. As Art.-No. 845001, but with rollers made of polyamide and pipe guides Ø 75 and 110 mm. Safety foot-switch. Ring spanner. With cutter wheel RF. For workbench, stand or wheel stand. In a carton. Art.-No. 845003 R220 £ 1,810.00

£ **1,659.00**

REMS DueCento – Cutting up to Ø 225 mm.

Right angled. Chip-free. Ready for welding. Fast. Without outside burr. Dry. Universal for many pipe types.

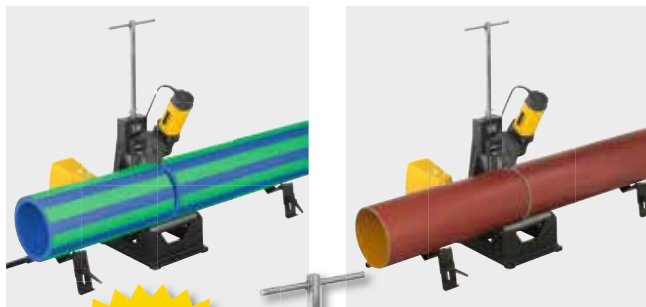

up to
Ø 225 mm



German quality product

FREE*



REMS DueCento Basic

Pipe cutting machine for fast, right angled cutting of pipes Ø 40–225 mm, without outside burr. For pipes of the press fitting systems made from stainless steel, carbon steel, copper, Ø 54–225 mm. For steel pipes EN 10255 (DIN 2440) DN 50–150, Ø 2–6", cast pipes (SML) EN 877 (DIN 19522) DN 50–200, plastic tubes SDR 11, wall thickness $s \leq 21$ mm, Ø 40–225 mm, Ø 1¼–8", composite tubes Ø 40–110 mm. With maintenance-free gears, proven universal motor 110 / 230 V, 50–60 Hz, 1,200 W. Speed 115 rpm. Hardened, precision tubular steel rollers for pipes Ø 100–225 mm, Ø 4–6". Safety foot switch. Ring spanner. Without cutter wheel. 2 height adjustable pipe supports 1 for pipes Ø 100–225 mm, Ø 4–8". In a carton.

Art.-No. 845004 R220 £ 2,220.00

Unique! Patent EP 1 782 904

Driven cutting wheel and straight in-feed for fast cutting

Patent EP 2 740 556 pending

REMS cutter wheel Cu-INOX

for pipes of press fitting systems made of stainless steel, copper, carbon steel
Art.-No. 845050 R

£ **81.30**

REMS cutter wheel Cu

especially for pipes of the press fitting systems made of copper
Art.-No. 845053 R

£ **81.30**

REMS cutter wheel St

for steel pipes, cast pipes (SML)
Art.-No. 845052 R

£ **81.30**

REMS cutter wheel V, s 10

for plastic and multilayer composite tubes, wall thickness $s \leq 10$ mm
Art.-No. 845051 R

£ **81.30**

REMS cutter wheel P, s 21

for plastic and multilayer composite tubes, wall thickness $s \leq 21$ mm
Art.-No. 845057 R

£ **103.00**

REMS cutter wheel C-SF

especially for pipes of the press fitting systems/push fitting systems of carbon steel, simultaneously produces a chamfer.
Art.-No. 845055 R

£ **81.30**

Pipe support 1

height adjustable for pipes Ø 100–225 mm, Ø 4–8"
Art.-No. 845220 R

£ **113.00**

Pipe support 2

height adjustable, for pipes Ø 40–110 mm, Ø 1¼–4" (roller insert required)
Art.-No. 845230 R

£ **113.00**

Roller insert

for cutting pipes Ø 40–100 mm, Ø 1¼–3½"
Art.-No. 845060 R

£ **179.00**

Super offer!

You get 3 cutting wheels of your choice free when you buy a REMS DueCento Basic!
An additional saving of between £ 243.90 and £ 309.00.

Art.-No. 845X03 R220 £ **1,999.00**



German quality product

Only 2.1 kg



REMS Akku-Nano – cutting up to Ø 40 mm.

Ultra-light. Fast. Right-angled. Chipless.
No outside burr. Dry.

Unique! Patent EP 2 077 175

Optimum engagement of the cutting wheel to the pipe to be cut.

REMS Akku-Nano Basic-Pack

Cordless pipe cutting machine for fast, right angled cutting of pipes Ø 10–40 mm, without outer burr. For pipes of the press fitting systems made of stainless steel, carbon steel, Ø 12–28 mm, copper Ø 10–35 mm. Multilayer composite tubes Ø 10–40 mm. With maintenance-free gear, powerful 10.8 V, 270 W battery motor. Speed 130 rpm. Safety switch. Li-Ion 10.8 V, 1.3 Ah battery, Li-Ion 110 V, 50–60 Hz rapid charger, 65 W. Back pressure rollers of hardened precision steel. Single open ended wrench size 8. Without cutting wheel. In carrying bag. Art.-No. 844011 R220 £ 550.00

£ **399.00**

REMS cutting wheel Cu-INOX

for pipes of press fitting systems made of:
stainless steel, carbon steel, copper

Art.-No. 844050 R

£ **28.00**

REMS cutting wheel V

for multilayer composite tubes

Art.-No. 844051 R

£ **28.00**

German quality product

Only 1.9 kg



REMS Nano – cutting up to Ø 40 mm.

Ultra-light. Fast. Right-angled. Chipless.
No outside burr. Dry.

Unique! Patent EP 2 077 175

Optimum engagement of the cutting wheel to the pipe to be cut.

REMS Nano Basic-Pack

Electric pipe cutting machine for fast, right angled cutting of pipes Ø 10–40 mm, without outer burr. For pipes of the press fitting systems made of stainless steel, carbon steel, Ø 12–28 mm, copper Ø 10–35 mm. Multilayer composite tubes Ø 10–40 mm. With maintenance-free gear, proven 110 V, 50–60 Hz, 130 W DC motor. Speed 130 rpm. Back pressure rollers made of hardened precision steel. Safety switch. Single open ended wrench size 8. Without cutting wheel. In carrying bag. Art.-No. 844010 R220 £ 401.00

£ **329.00**

REMS cutting wheel Cu-INOX

for pipes of press fitting systems made of:
stainless steel, carbon steel, copper

Art.-No. 844050 R

£ **28.00**

REMS cutting wheel V

for multilayer composite tubes

Art.-No. 844051 R

£ **28.00**

REMS REG – Robust quality tool for removing outer and inner burr from pipes.

For stainless steel pipes, other steel pipes, copper, brass, aluminium and plastic pipes.

REMS REG 8–35

Outer/inner pipe burr remover for pipes Ø 8–35 mm, ¼–1¼".
Art.-No. 113825 R £ 49.10

£ **39.00**

REMS REG 10–54

Outer/inner pipe burr remover for pipes Ø 10–54 mm, ½–2¼".
Art.-No. 113830 R £ 56.00

£ **47.00**

Patent EP 2 058 067

REMS REG 10–54 E – also for electric drive

Outer/inner pipe burr remover for pipes Ø 10–54 mm, ½–2¼". Also for electric drive by REMS Helix (see page 10) and other power drills/screwdrivers (speed ≤ 300 rpm), by the pipe cutting machine REMS Cento (from date of manufacture 09/2011) or by the pipe circular sawing machine REMS Turbo Cu-INOX (from date of manufacture 09/2011).
Art.-No. 113835 R £ 103.00

£ **82.00**





1.5Ah / 2.5Ah

- Li-Ion 21.6V battery with 1.5 or 2.5 Ah capacity for long service life.
- Even more efficient: 50 % more pressings!²⁾
 - Li-Ion 21.6V, 1.5Ah battery for approx. 250 pressings Viega Profipress DN 15 per battery charge.
 - Li-Ion 21.6V, 2.5Ah battery for approx. 390 pressings Viega Profipress DN 15 per battery charge.
- Low weight.
- Extended operating temperature range – 10 to +60 °C.
- Total discharge and overload protection with single cell monitoring.
- Temperature monitoring during the charging process.
- Short charging times.

NEW

REMS Mini-Press 22V ACC and REMS Mini-Press S 22V ACC –
The real one-hand radial presses! Universal up to Ø 40 mm.
Ultra-light. Ultra-small. Ultra-handly. Ultra-fast.
360° rotatable.



Extremely "mini"
< 31 cm (V 15)

Patent EP 1 952 948
Very compact design and low weight of the REMS Mini pressing tongs due to special arrangement of the pressing tongs connection.

Patent EP 2 347 862
Recesses in the pressing jaws for safe guidance of the connecting plate for offset-free pressing.



REMS Mini-Press 22V ACC / Mini-Press S 22V ACC

Cordless radial press with automatic circuit control for producing pipe pressing joints Ø 10–40 mm, Ø ¼–1 ¼". For operating with REMS pressing tongs Mini/pressing rings. Swivelling pressing tongs seat with automatic locking. Electro-hydraulic drive with powerful battery motor 21.6 V, 380 W, robust planetary gear, eccentric reciprocating pump and compact high power hydraulic system, safety switch. Integrated LED work light. Battery Li-Ion 21.6 V, 1.5 Ah, rapid charger Li-Ion 230 V or 110 V, 50–60 Hz, 70 W.



only 2.5 kg

German quality product

only 2.6 kg

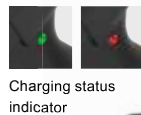

Charging status indicator



FREE

Extra battery Li-Ion 21.6V, 1.5Ah

Art.-No. 571570 £ 185.00



REMS Mini-Press 22V ACC Basic-Pack

In sturdy steel case.
Art.-No. 578010 R220 £ 1,390.00

£ **1,029.00**

REMS Mini-Press 22V ACC Basic-Pack L-BOX

In L-Boxx system case.
Art.-No. 578014 R220 £ 1,420.00

£ **1,069.00**

REMS Mini-Press S 22V ACC Basic-Pack

In sturdy steel case.
Art.-No. 578015 R220 £ 1,390.00

£ **1,029.00**

REMS Mini-Press S 22V ACC Basic-Pack L-BOX

In L-Boxx system case.
Art.-No. 578016 R220 £ 1,420.00

£ **1,069.00**

¹⁾ Warranty conditions and registration for extension of the manufacturer's warranty to 5 years under www.rems.de/service

²⁾ Li-Ion 21.6V battery in comparison with Li-Ion 14.4V battery

←ACC→

Automatic Circuit Control
with automatic retraction

German quality product

REMS TECHNOLOGY
LITHIUM PLUS

LED



only 2.4 kg

Charging status indicator



LED work light



Only 2.4 kg! Universal up to Ø 40 mm.
Ultra-light. Ultra-small. Ultra-handly.
Ultra-fast. 360° rotatable.

REMS Mini-Press ACC Basic-Pack

Cordless radial press with automatic return after completed pressing cycle (forced process), for producing press connections Ø 10–40 mm, Ø ¼–1¼". For driving REMS Mini pressing tongs/pressing rings. Rotating pressing tongs seat with automatic locking. Electro-hydraulic drive with powerful 14.4 V, 380 W battery motor, robust planetary gear, eccentric reciprocating pump and compact high power hydraulic system, safety switch. Integrated LED work light. Li-Ion 14.4 V, 1.5 Ah battery, Li-Ion/Ni-Cd 110 V / 230 V, 50–60 Hz, 65 W rapid charger. In sturdy steel case.

Art.-No. 578012 R220 £ 1,160.00



+ gift package with a value of £ 167.10
1 REMS cordless LED lamp;
extra battery Li-Ion 14.4 V, 1.5 Ah
Value £ 1,327.10

Art.-No. 578X02 R220 £ **875.00**

←ACC→

Automatic Circuit Control
with automatic retraction

German quality product

REMS TECHNOLOGY
LITHIUM PLUS

LED



only 4.3 kg

Charging status indicator



LED work light



Universal up to Ø 110 mm. Compact.
Handy. Ultra-fast. 360° rotatable.

REMS Akku-Press Basic-Pack

Cordless radial press with switch-off signal after completed pressing cycle, for producing press connections Ø 10–108 (110) mm, Ø ¼–4". Li-Ion 14.4 V, 3.0 Ah battery, Li-Ion/Ni-Cd 110 V, 50–60 Hz, 65 W rapid charger. In sturdy steel case.

Art.-No. 571013 R220 £ 1,170.00

Art.-No. 571X01 R220 £ **959.00**

REMS Akku-Press ACC Basic-Pack

Cordless radial press with automatic return after completed pressing cycle (forced process), for producing press connections Ø 10–108 (110) mm, Ø ¼–4". See above for rest of delivery scope.

Art.-No. 571014 R220 £ 1,330.00

Art.-No. 571X02 R220 £ **999.00**



+ Gift package with every Basic-Pack:
1 cordless LED lamp
extra Li-Ion 14.4 V, 3.0 Ah battery
Value £ 212.10

←ACC→

Automatic Circuit Control
with automatic retraction

German quality product



only 4.7 kg

LED



Universal up to Ø 110 mm. Compact.
Handy. Ultra-fast. 360° rotatable.

REMS Power-Press Basic-Pack

Electro-hydraulic radial press with switch-off signal after completed pressing cycle, for producing press connections Ø 10–108 (110) mm, Ø ¼–4". For driving REMS pressing tongs/pressing rings and other suitable makes of pressing tongs/pressing rings. Rotating pressing tongs seat with automatic locking. Electro-hydraulic drive with proven 110 V, 50–60 Hz, 450 W universal motor, robust planetary gear, eccentric reciprocating pump and compact high performance hydraulic system, safety switch. In sturdy steel case.

Art.-No. 577011 R220 £ 1,020.00

£ **899.00**

REMS Power-Press ACC Basic-Pack

Electro-hydraulic radial press with automatic return after completed pressing cycle (forced process), for producing press connections Ø 10–108 (110) mm, Ø ¼–4". See above for rest of delivery scope.

Art.-No. 577010 R220 £ 1,130.00

£ **919.00**

German quality product

only 4.7 kg



REMS Power-Press SE – universal up to Ø 110 mm. Reliable pressing in seconds.

REMS Power-Press SE Basic-Pack

Electric radial press for production of press connections Ø 10–108 (110) mm, Ø ¼–4". For driving REMS pressing tongs/pressing rings and other suitable other makes of pressing tongs/pressing rings. Pressing tongs seat with automatic locking. Electro-mechanical drive with proven universal motor 110 / 230 V, 50–60 Hz, 450 W, maintenance-free gear with safety slipping clutch and in-feed system with machine screw spindle. Overload protection, safety switch. In sturdy steel case.

Art.-No. 572111 R220 £ 780.00



£ **679.00**

German quality product



only 1.6 kg

REMS Eco-Press – universal up to Ø 26 mm. Ultra-fast, reliable pressing.

REMS Eco-Press drive device

Manual radial press with locking end stop for producing press connections with plastic and multilayer composite tubes Ø 10–26 mm. For driving REMS pressing tongs. With dividable pipe arms. In skin packing.

Art.-No. 574000 R

£ **171.00**

Unique!

Patent EP 1 223 008

All the REMS pressing tongs marked by * in the catalogue have another connection and also fit the REMS Eco-Press manual radial press. Thus simple, inexpensive stocking.

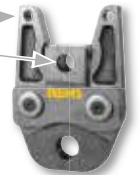

REMS pressing rings for large dimensions. Fit. Press. Finished.



German quality product

REMS pressing rings (PR-3S) with 3 swivellable pressing formers mounted on a jointed ring for large dimension complex pressings. Optimum pressing by radially controlled movement of the pressing formers. Pressing contour M for Geberit Mapress and other suitable systems.

REMS pressing ring M42 (PR-3S)	Art.-No. 572706 R	£ 530.00
REMS pressing ring M54 (PR-3S)	Art.-No. 572708 R	£ 530.00
Intermediate tongs Z2 for driving REMS pressing rings (PR-3S) 42–54 mm	Art.-No. 572795 RX	£ 114.00
Steel case	Art.-No. 572810 R	£ 71.10
Pressing ring set complete	Art.-No. 572060 R	£ 1,250.00

£ **999.00**

REMS Power-Press XL ACC – universal up to Ø 110 mm.

Also for Geberit Mapress C-STEEL, STAINLESS STEEL, COPPER in drinking water and heating installation up to Ø108 mm.

Pressing up to Ø 110 mm in just one action. Ultra-fast, e.g. Geberit Mapress STAINLESS STEEL Ø 108mm in only 15 seconds. For driving REMS pressing tongs/pressing rings/XL pressing rings and other suitable makes of pressing tongs/pressing rings. Rotating pressing tongs seat with automatic locking.



←ACC→

Automatic Circuit Control

with automatic retraction

German quality product



REMS Power-Press XL ACC Basic-Pack

Electro-hydraulic radial press with automatic circuit control for making press joints Ø 10–108 (110) mm, Ø 3/4–4". For driving REMS pressing tongs/pressing rings/XL pressing rings and other suitable makes of pressing tongs/pressing rings. Rotating pressing tongs seat with automatic locking. Electro-hydraulic drive with proven 230 V, 50–60 Hz, 450 W universal motor, robust planetary gear, eccentric reciprocating pump and compact high power hydraulic system, safety inching switch. In transport case. Art.-No. 579010 R220

£ **1,820.00**

E.g. for Geberit Mapress C-STEEL, STAINLESS STEEL, COPPER press fitting systems in drinking water and heating installation up to Ø108 mm.

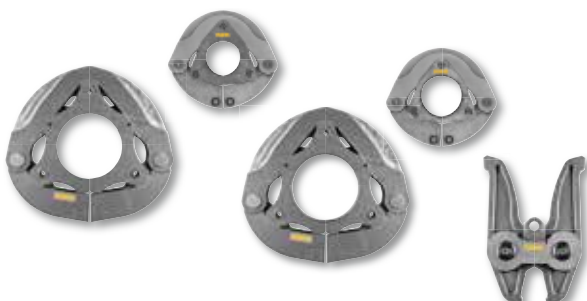

REMS XL pressing rings (PR-3S)

Heavy duty XL pressing rings XL (PR-3S) and Z6 XL adapter tongs made of forged and specially hardened special steel. The pressing contours of the REMS XL pressing rings (PR-3S) are system-specific and correspond to the pressing contours of the respective press fitting systems. Perfect system-conformant, reliable pressing as a result.

M 66,7 XL (PR-3S)²⁾

Art.-No. 579107 R

£ **880.00**

M 76,1 XL (PR-3S)²⁾

Art.-No. 579101 R

£ **930.00**

M 88,9 XL (PR-3S)²⁾

Art.-No. 579102 R

£ **980.00**

M 108,0 XL (PR-3S)²⁾

Art.-No. 579103 R

£ **1,030.00**

Z6 XL adapter tongs

For driving the REMS pressing rings M 64.0–108.0 XL (PR-3S) with REMS Power-Press XL

Art.-No. 579120 R

£ **320.00**

²⁾The Z6 XL pressing tongs are required for driving the XL pressing rings (PR-3S).

Unique!

Patent EP 1 223 008

All the REMS pressing tongs marked by * in the catalogue have another connection and also fit the REMS Eco-Press manual radial press. Thus simple, inexpensive stocking.

Patent EP 2 027 971

REMS Mini ACz, Fz, RFz, RFlz pressing tongs with teeth prevent formation of burr on the pressing sleeve.

German quality product

With this traceability REMS fulfils the recommendations of the European standard EN 1775:2007 for the installation of pressfitting systems for gas.

Example REMS pressing tongs M: Impression "M" on pressed fitting for traceability according to EN 1775:2007

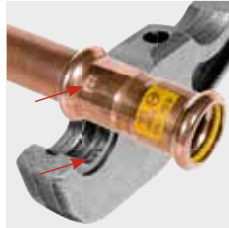

REMS pressing tongs – Proven a million times over. For all common press fitting systems.

Highly durable pressing tongs made of forged, tenacious, specially hardened special steel. The pressing contours of the REMS pressing tongs are system-specific and correspond to the pressing contours of the respective press fitting systems. Perfect system-conformant, reliable pressing as a result. Pressing jaws of the pressing tongs with high-precision cut and exactly rounded pressing contour on CNC machining centres. Much lower production tolerances than only cast pressing contour as a result.

Traceability according to EN 1775:2007

REMS pressing tongs/pressing rings with pressing contour M, V, SA, B, HR and UP have worked a specific marking into the pressing contour which leaves a lasting impression on the pressed fitting after the pressing process. This enables the user to check again whether the most suitable pressing tongs or the suitable pressing ring have been used to make the pressfit connection even after the pressing process.

REMS pressing tongs / pressing tongs Mini M, V up to 35 mm

£ **90.00**

REMS pressing tongs / pressing tongs Mini up to 32 mm. TH, U, UP, VP, G, B

£ **96.00**

REMS pressing rings 45° (PR-2B) – the problem solution for places with difficult access.

e.g. opened walls, exposed pipes, shafts

Patent EP 2 774 725

REMS pressing ring 45° (PR-2B), with 2 pressing jaws, for secure engagement of the pressing jaws in places of difficult access by 45° inclination.



German quality product



REMS pressing rings 45° (PR-2B)

Pressing contour	Art.-No.	£	Pressing contour	Art.-No.	£
V 12 45° (PR-2B)	574502 R	95.80	M 12 45° (PR-2B)	574520 R	95.80
V 14 45° (PR-2B)	574532 R	95.80	M 15 45° (PR-2B)	574522 R	95.80
VG 14 45° (PR-2B)	574536 R	95.80	M 18 45° (PR-2B)	574524 R	95.80
V 15 45° (PR-2B)	574504 R	95.80	M 22 45° (PR-2B)	574526 R	95.80
V 16 45° (PR-2B)	574534 R	95.80	M 28 45° (PR-2B)	574528 R	95.80
VG 16 45° (PR-2B)	574538 R	95.80	M 35 45° (PR-2B)	574530 R	107.00
V 18 45° (PR-2B)	574506 R	95.80	F 16 45° (PR-2B)	574550 R	95.80
V 22 45° (PR-2B)	574508 R	95.80	F 20 45° (PR-2B)	574552 R	95.80
V 28 45° (PR-2B)	574510 R	95.80	F 26 45° (PR-2B)	574554 R	95.80
V 35 45° (PR-2B)	574512 R	107.00	F 32 45° (PR-2B)	574556 R	95.80

REMS Mini adapter tong Z1

for driving REMS pressing rings 45° (PR-2B). Suitable for REMS Mini-Press ACC, REMS Mini-Press 22V ACC, REMS Mini-Press S 22V ACC.

Art.-No. 578558 RX £ **114.00**

REMS adapter tong Z1

for driving REMS pressing rings 45° (PR-2B). Suitable for all REMS radial presses (except REMS Mini-Press ACC, REMS Mini-Press 22V ACC, REMS Mini-Press S 22V ACC).

Art.-No. 574500 RX £ **114.00**

Steel case

with insert (for adapter tong Mini Z1 and adapter tong Z1 and 6 REMS pressing rings V 12 – 35 45° (PR-2B) or M 12 – 35 45° (PR-2B))

Art.-No. 574516 R £ **71.10**

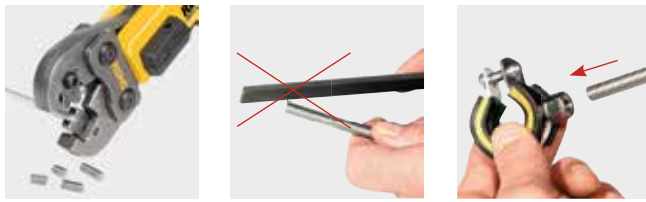

Cropping tongs with 1 pair of reversible cutting inserts for steel, stainless steel, M 6–M 12, up to strength class 4.8 (400 N/mm²).



German quality product

REMS cropping tongs M – cutting threaded bars. Ultra-fast.

Unique! – Patent EP 1 223 008

All cropping tongs marked by * have another connection for manual drive by the manual radial press REMS Eco-Press. Thus simple, inexpensive stocking.

For REMS Mini-Press ACC, REMS Mini-Press 22V ACC, REMS Mini-Press S 22V ACC:

REMS Mini cropping tongs – cuts in just 2 seconds!

M 6	Art.-No. 578620	
M 8	Art.-No. 578621	
M 10	Art.-No. 578622	instead of £ 186.00 now only

For REMS radial presses (except REMS Mini-Press ACC, REMS Mini-Press 22V ACC, REMS Mini-Press S 22V ACC) and suitable radial presses of other makes:

REMS cropping tongs

M 6*	Art.-No. 571890	
M 8*	Art.-No. 571895	
M 10	Art.-No. 571865	
M 12	Art.-No. 571870	instead of £ 186.00 now only

£ **139.00**

REMS pressing tongs/rings for Viega MegaPress

Drive by all REMS radial presses (except REMS Mini-Press ACC, REMS Mini-Press 22V ACC, REMS Mini-Press S 22V ACC.) and suitable radial presses of other makes.

REMS pressing tongs/rings VMP 3/8", 1/2", VMPz 3/4–2"

VMP 3/8" (OD 17,2mm)	Art.-No. 571740	£ 164.00
VMP 1/2" (OD 21,3mm)	Art.-No. 571762	£ 164.00
VMPz 3/4" (OD 26,9mm)	Art.-No. 571764	£ 164.00
VMPz 1" (OD 33,7mm)	Art.-No. 571767	£ 164.00
VMPz 1 1/4" (S) (OD 42,4mm)	Art.-No. 572413	£ 540.00
VMPz 1 1/2" (PR-3B)¹⁾ (OD 48,3mm)	Art.-No. 572844 R	£ 371.00
VMPz 2" (PR-3B)¹⁾ (OD 60,3mm)	Art.-No. 572845 R	£ 371.00

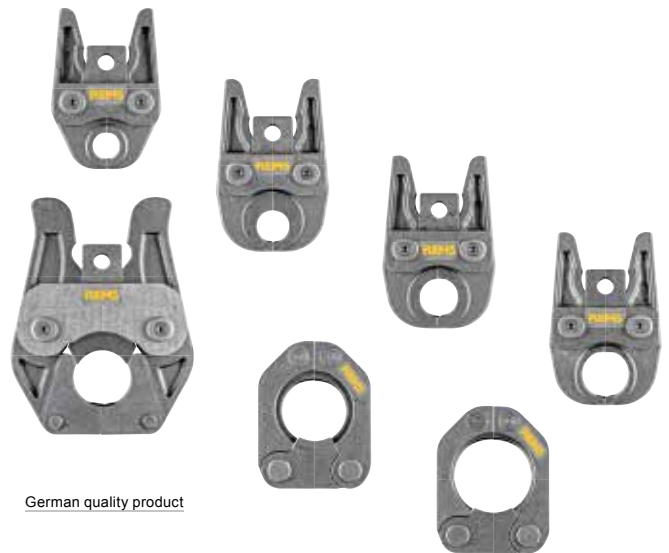

German quality product

Adapter tongs Z5

for driving the REMS pressing rings (PR-3B) VMPz 1 1/2 – 2"
Art.-No. 572802 RX

£ **268.00**

¹⁾The Z5 adapter tongs are required for driving the pressing rings.



German quality product

REMS cable shear – Easy cutting of electric cable.



Made of forged and specially hardened steel. Replaceable cutting blades manufactured on CNC production centres ensure a precision blade geometry and long service life. Large cutting range. Drive through electric REMS radial presses (except REMS Mini-Press ACC, REMS Mini-Press 22V ACC, REMS Mini-Press S 22V ACC) and through suitable radial presses of other makes.

REMS cable shear

Cable shears with 2 changeable cable cutters for electric cables
≤ 300 mm² (Ø 30 mm). In a carton.
Art.-No. 571887 £ 309.00

£ **199.00**

REHAU, TECE ...

NEW



only 3.0kg

← ACC →

Automatic Circuit Control

with automatic retraction and charging status indicator

German quality product



LED work light

e. g.
aquatherm,
IVT,
Prandelli,
REHAU,
REVEL,
ROTEX,
TECE,
Würth



REMS Ax-Press 25 22 V ACC – universal up to Ø 40 mm. Ultra-light, ultra-small, ultra-handly. Ultra-fast. With automatic return. Optimum weight distribution for one-hand operation. Rotating pressing device.

REMS Ax-Press 25 22 V ACC Basic-Pack

Cordless axial press for producing compression sleeve joints Ø 12–40 mm. 40 mm stroke, for pressing compression sleeve connections with a clamping distance ≤ 82 mm. For driving REMS pressing heads. Electro-hydraulic drive with powerful battery motor 21.6 V, 380 W, robust planetary gear, eccentric reciprocating pump and compact high power hydraulic system, safety tip switch, swivelling pressing device. Integrated LED work light. Battery Li-Ion 21.6 V, 1.5 Ah, rapid charger Li-Ion 230 V or 110 V, 50–60 Hz, 70 W. Without compression heads.

In sturdy steel case.

Art.-No. 573022 R220 £ 1,160.00



3 sets of pressing heads of your choice free
Save between £ 237.30 and £ 357.00.

Art.-No. 573X03 R220 £ **995.00**

Heating elements according to DVS
High quality PTFE coating



REMS MSG – rational sleeve welding



REMS MSG 63 EE Set 20-25-32

Heating element sleeve welding device for plastic tubes and mouldings made of PB, PE, PP, PVDF. Heating element 110 V, with PTFE-coated heating nozzles, heating sleeves for Ø 20, 25, 32 mm. Fixed temperature for PP tubes set to 260°C, with mechanical temperature regulation. Shelf stand. Holder for workbench for fastening the device in a horizontal or vertical position. Allen key for assembling and disassembling the heating nozzles and heating sleeves.

In sturdy steel case.

Art.-No. 256240 R110G £ 730.00

£ **399.00**



REMS SSM 160KS.

Heating element according to DVS. Electronic temperature control. High quality PTFE coating. Closed plane housing. With quick clamping device, also for angled outputs.

REMS SSM 160KS

Heating element butt welding machine for plastic tubes and mouldings made of PB, PE, PP, PVDF. PE Ø 40–90 mm SDR ≥ 6, PE Ø 40–110 mm SDR ≥ 9, PE Ø 40–125 mm SDR ≥ 11, PE Ø 40–140 mm SDR ≥ 17, PE Ø 40–160 mm SDR ≥ 21. Heating element butt welding device with PTFE-coated heating element 110 V, 50–60 Hz, 1200 W. Adjustable temperature 180–290°C, preset for PE tubes. Electronic temperature control. Protective cover for heating element. Electrical planing device 230 V, 50–60 Hz, 500 W. Pressing device. Quick clamping device, also for inclined outlets, consisting of 2 vices with 2 clamping inserts each Ø 40, 50, 56, 63, 75, 90, 110, 125, 135, 140 mm. 2 pipe rests Ø 160 mm with pipe rest inserts Ø 40, 50, 56, 63, 75, 90, 110, 125, 135, 140 mm. Sheet steel base with installed drawer. Operating key. Closed sheet steel underframe = transport box.

Art.-No. 252046 R110G £ 5,190.00

£ **4,289.00**

¹⁾ Warranty conditions and registration for extension of the manufacturer's warranty to 5 years under www.rems.de/service

up to
2"



German quality product

*ambient/water temperature approx. 18°C.

REMS Eskimo – freezing instead of draining. Super fast. Automatic refrigerant feed.

Very narrow, indestructible freezing sleeves.
High cooling performance, e.g. 3/4" steel pipe in just 5 min.*

REMS Eskimo Set

Pipe freezing device for carbon dioxide coolant. For steel, cast iron, lead, copper, plastic pipes Ø 1/4–2", Ø 10–60 mm. Two freezing jackets each in 10 different sizes for the whole working range, flange connection with T-junction, locking nut, 2 handles with injector, 2 high-pressure hoses. In sturdy carrying case.

Art.-No. 130002 R £ 463.00

£ **319.00**

up to
2"



High cooling performance,
e.g. 3/4" steel pipe in just 9 min*.

German quality product

*ambient/water temperature approx. 18°C.

REMS Frigo 2 – electrically freeze instead of emptying. Ultra-fast up to 2".

Unique! Patent EP 1 108 944

One-piece freezing heads for the main working range Ø 1/4 – 1" or Ø 15 – 35 mm, no reducer inserts required. Very compact freezing heads with specially geometrically designed recesses for holding the respective different pipe diameters. Very narrow, only 50 mm wide. Can be used everywhere, even in narrow places. No pastes/greases required.

REMS Frigo 2 Set

Electrical pipe freezing device with closed coolant circuit. For steel, copper, plastic, multilayer composite pipes, Ø 1/4–2", Ø 10–60 mm. Cooling unit 110 V, 50 Hz, 430 W, 2 coolant hoses, 2 clamping straps, 2 LCD digital thermometer, spray bottle. Equipment for Ø 1/4–1 1/4", 15–42 mm. In sturdy steel housing. In a carton.

Art.-No. 131011 R220 £ 1,300.00

£ **919.00**



Upgrade kit 1 1/2–2" / 54–60 mm

Art.-No. 131160 R

£ **207.00**



German quality product

REMS Spezial – high alloy thread cutting oil

Mineral oil-based, can be washed out with water.

REMS Spezial canister 5 l

Art.-No. 140100 R £ 51.40

£ **33.90**

REMS Spezial spray 600 mly

Art.-No. 140105 R £ 17.50

£ **11.40**



REMS Sanitol – mineral oil-free thread cutting oil.

Completely soluble in water. According to DVGW, ÖVGW, SVGW regulations. Dyed red for wash-out check. Excellent corrosion protection.

REMS Sanitol canister 5 l

Art.-No. 140110 R £ 71.00

£ **48.50**

REMS Sanitol spray 600 ml

Art.-No. 140115 R £ 19.00

£ **14.50**



7808-649



W 1.303



DW-0201AS2032

REMS eva – the die stock for professionals.

Very easy starting and thread cutting by precision processing of the die head, dies and cover in a compact unit. Ratchet lever of steel, thick plastic jacket.



German quality product

REMS Eva Set R 1/2-3/4-1-1 1/4

Manual die stock with quick-change die heads. For pipe threads 1/2–2", 16–50 mm, bolt threads 6–30 mm, 1/4–1". For right and left-hand threads. 1 ratchet lever for the entire cutting range. Quick-change die heads R 1/2-3/4-1-1 1/4 with dies for conical pipe threads ISO 7-1, EN 10226 (DIN 2999, BSPT) R right-hand. In sturdy steel case.

Art.-No. 520015 £ 359.00

£ **299.00**

REMS Eva Set R 1/2-3/4-1-1 1/4-1 1/2-2

Manual die stock with quick-change die heads R 1/2-3/4-1-1 1/4-1 1/2-2. In sturdy steel case.

Art.-No. 520017 £ 550.00

£ **389.00**

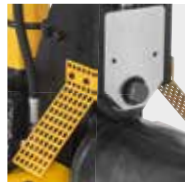

German quality product

REMS Herkules 3B
(Accessory)

Wheel stand
(Accessory)

Stand

Art. No. 849315 R £ **162.00**

Wheel stand

Art. No. 849310 R £ **261.00**

REMS Herkules 3B

Material support, height adjustable, for pipes DN 25–150, Ø 1–6"

Art. No. 120120 R £ **250.00**

REMS Collum RG – Electric roll groover up to 12".

REMS Collum RG

Roll grooving machine for grooving pipes for pipe coupling systems DN 25–300, 1–12". Roll grooving attachment, manual hydraulic pump, integrated, graduated ring gauge for automatic groove depth stop, 1 pair of grooving rollers (pressure roller, counterpressure roller) 2–6", Allen key. Choice of 3 drive units, with maintenance-free gear, powerful universal motor, safety switch. For workbench, stand or wheel stand. In a carton.

REMS Collum RG

Universal motor 230 V, 50–60 Hz, 1200 W, overload protection. 29 min⁻¹.

Art. No. 347006 R220 £ 2,110.00

£ **1,849.00**

REMS Collum RG 2

Universal motor 230 V, 50–60 Hz, 1700 W. 28 min⁻¹

Art. No. 347008 R220 £ 2,420.00

£ **1,949.00**

REMS Collum RG 2 Compact

Universal motor 230 V, 50–60 Hz, 1200 W, overload protection. 26 min⁻¹

Art. No. 347009 R220 £ 2,420.00

£ **2,049.00**

REMS roller groove device

Art.-No. 347000 R £ 1,790.00

£ **1,429.00**

REMS Tornado – a class on its own.

Automatic clamping chuck
Universal automatic die head
Automatic lubrication cooling

REMS Tornado 2000

Threading machine for pipe threads (1/16) 1/8–2", 16–63 mm, bolt threads (6) 10–60 mm, 1/4–2". With maintenance-free gear, safety foot switch with emergency stop, 2 automatic clamping chucks, automatic lubrication cooling. With tool set, consisting of a universal automatic die head for all threads, including long threads, automatically opening, with automatic thread length for conical threads, dies for conical pipe thread, ISO 7-1, EN 10226 (DIN 2999, BSPT) R 1/2–3/4 and R 1–2 right, pipe cutter, pipe inside burr remover, pressing lever. Height-adjustable material shelf. 110 V, 50–60 Hz, 1700 W universal motor. 53 rpm. Portable version on tripod, with large, removable oil basin and chip tray.

Art.-No. 340200 R220

£ 3,620.00

+ 1 REMS Spezial oil 5 l

Art.-No. 140100 R

£ 51.40

£ **3,671.40**

£ **1,999.00**

German quality product



With universal automatic die head, automatically opening.

German quality product



REMS Magnum – the compact one up to 2". Favourable dimensions, good weight. Excellent round and clean thread.

REMS Magnum 2000 L-T

Threading machine for pipe threads ($\frac{1}{16}$) $\frac{1}{4}$ –2", 16–63 mm, bolt threads (6) 8–60 mm, $\frac{1}{4}$ –2". With maintenance-free gear, safety foot switch with emergency stop, proven, self-reinforcing quick-clamping centring chuck, automatic lubrication cooling. With tool set, consisting of a universal automatic die head for all threads, including long threads, automatically opening, with automatic thread length for conical threads, dies for conical pipe thread ISO 7-1, EN 10226 (DIN 2999, BSPT) R $\frac{1}{2}$ – $\frac{3}{4}$ and R 1–2 right, pipe cutter, pipe inside burr remover, pressing lever. Tool shelf. Lightweight version L-T with removable, large oil basin and chip tray. 110 V, 50–60 Hz, 1700 W universal motor. 53 rpm. For workbench, stand, collapsible wheel stand or wheel stand with material shelf. In a carton.

Art.-No. 340226 R110

£ 3,690.00

+ REMS wheel stand

Art.-No. 344100 R

£ 360.00

+ 1 REMS Spezial oil 5 l

Art.-No. 140100 R

£ 51.40

£ 4,101.40

£ **2,299.00**



Collapsible wheel stand

Art.-No. 344150 R

£ 411.00

With universal automatic die head, automatically opening.

German quality product



REMS Magnum – the super machine up to 3". Excellent round and clean thread up to 3" by 5 dies.

REMS Magnum 3000 L-T

Threading machine for pipe threads ($\frac{1}{16}$) $\frac{1}{2}$ –3", 16–63 mm, bolt threads (6) 20–60 mm, $\frac{1}{2}$ –2". With maintenance-free gear, safety foot switch with emergency stop, proven, self-reinforcing quick-clamping centring chuck, automatic lubrication cooling. Machine complete with tool sets $\frac{1}{16}$ –2" and 2 $\frac{1}{2}$ –3", consisting respectively of universal automatic die head for all threads, including long threads, automatically opening, with automatic thread length for conical threads, dies for conical pipe threads ISO 7-1, EN 10226 (DIN 2999, BSPT) R right, pipe cutter, pipe inside burr remover, pressing lever. Tool shelf. Lightweight version L-T with removable, large oil basin and chip tray. 110 V, 50–60 Hz, 1700 W universal motor. 23 rpm. For workbench, stand, collapsible wheel stand or wheel stand with material shelf. In a carton.

Art.-No. 380309 R110

£ 5,330.00

+ REMS wheel stand

Art.-No. 344100 R

£ 360.00

+ 1 REMS Spezial oil 5 l

Art.-No. 140100 R

£ 51.40

£ 5,741.40

£ **3,049.00**



Collapsible wheel stand

Art.-No. 344150 R

£ 411.00

With universal automatic die head, automatically opening.

German quality product



REMS Magnum – the super machine up to 4". Excellent round and clean thread up to 4" by 6 dies.

REMS Magnum 4000 L-T

Threading machine for pipe threads ($\frac{1}{16}$) $\frac{1}{2}$ –4", 16–63 mm, bolt threads (6) 20–60 mm, $\frac{1}{2}$ –2". With maintenance-free gear, safety foot switch with emergency stop, proven, self-reinforcing quick-clamping centring chuck, automatic lubrication cooling. With tool sets $\frac{1}{16}$ –2" and 2 $\frac{1}{2}$ –4", consisting respectively of universal automatic die head for all threads, including long threads, automatically opening, with automatic thread length for conical threads, dies for conical pipe threads ISO 7-1, EN 10226 (DIN 2999, BSPT) R right, pipe cutter, pipe inside burr remover, pressing lever. Tool shelf. Lightweight version L-T with removable, large oil basin and chip tray. 110 V, 50–60 Hz, 1700 W universal motor. 23 rpm. For workbench, stand or wheel stand with material shelf. In a carton.

Art.-No. 380444 R110

£ 6,110.00

+ REMS wheel stand

Art.-No. 344100 R

£ 360.00

+ 1 REMS Spezial oil 5 l

Art.-No. 140100 R

£ 51.40

£ 6,521.40

£ **3,899.00**



Collapsible wheel stand

Art.-No. 344150 R

£ 411.00

REMS Amigo E – the lightest, strongest and fastest up to 1".



950 W
only 3.4 kg

German quality product



REMS Amigo E Set M 20-25-32

Electric die stock with quick-change die heads. For pipe threads ¼–1", 16–32 mm, for right and left-hand threads. Drive machine with maintenance-free gear, powerful 110 V, 50–60 Hz, 950 W universal motor, safety switch, power boosting automatic carbon brush adjustment in the direction of rotation selection. Peak consumption up to 1500 W. Right and left-hand rotation. Support bracket for both directions of rotation. REMS eva quick-change die heads for threads for electrical installation pipes DIN EN 60423 M. In sturdy steel case.
Art.-No. 530014 R220 £ 740.00

£ **418.00**

REMS Amigo – The smallest, lightest, strongest and fastest up to 1¼".



1200 W
Only 3.5 kg

German quality product



REMS Amigo Set M 16-20-25-32

Electric die stock with quick-change die heads. For pipe threads ¼–1¼", 16–40 mm, bolt threads 6–30 mm, ¼–1". For right and left-hand threads. Drive machine with maintenance-free gear, powerful universal motor 110 V, 50–60 Hz, 1200 W, safety switch, power boosting automatic carbon brush adjustment in the direction of rotation selection. Peak consumption up to 1800 W. Right and left-hand rotation, overload protection. Support bracket for both directions of rotation. REMS eva quick-change die heads for threads for electrical installation pipes DIN EN 60423 M. In sturdy steel case.
Art.-No. 530022 R220 £ 870.00

£ **529.00**

REMS Amigo 2 – extremely strong up to 2".



1700 W
Only 6.5 kg

German quality product



REMS Amigo 2 Set R ½-¾-1-1¼-1½-2

Electric die stock with quick-change die heads. For pipe threads ½–2", 16–50 mm, bolt threads 6–30 mm, ¼–1". For right and left-hand threads. Drive machine with maintenance-free gear, powerful 110 V, 50–60 Hz, 1700 W universal motor, safety switch, power boosting automatic carbon brush adjustment in the direction of rotation selection, right and left-hand rotation. Support bracket for both directions of rotation. REMS eva quick-change die heads for conical pipe threads ISO 7-1, EN 10226 (DIN 2999, BSPT) R ½-¾-1-1¼-1½-2 right. In sturdy steel case.
Art.-No. 540020 R220 £ 1,310.00

£ **855.00**

REMS Amigo 2 Set + REMS Aquila 3B

Value £ 1,701.00

Art.-No. 540X01 R220 £ **1,099.00**

REMS Secco – for drying and dehumidification.

Powerful, highly efficient air dehumidifier/building drier for drying rooms, e.g. after mains water damage, flooding, dehumidification of damp cellar rooms etc. and for fast drying of concrete, masonry, plaster and screed for example. For commercial use in trade and industry.

Dehumidification rate ≤ 80l/24h
Air volume ≤ 850m³/h



Design

Compact, handy construction in robust, powder-coated sheet steel housing. Weight 54 kg. Large air extraction areas with washable air filter. Electronic hygrostat for regulating the desired humidity: Switches off automatically on reaching the nominal humidity, switches back on automatically when humidity rises. Side air outlet for optimum air circulation. Hose for draining condensation into an internal 11.5 l condensation tank (accessory), extendible at the side, for draining condensation into a tank to be provided or directly into the drain system. On/Off switch for operation with and without internal 11.5 litre condensation tank. Automatic switch-off with switch-off signal when using the internal 11.5 litre condensation tank on reaching the maximum condensation filling level. Operating hours counter and electricity meter, e.g. for reporting to the damage regulator/customer. Device socket for detachable connecting cable. Practical compartment for the connecting cable during transport. Sturdy, mobile tubular steel frame with large castors for easy transport, also over steps.

Easy glide down and pull-up of the machine over the back of the tubular steel frame, e.g. from and onto the loading platform of a vehicle.

Chiller unit

High dehumidification rate by high quality chiller unit with highly efficient rotary compressor and high performance condensation motor 230 V, 1,200 W with automatic hot-gas thawing system, for continuous operation. Very quiet running, also suitable for living rooms. Dehumidification rate ≤ 80l/24h, air volume ≤ 850m³/h. High quality coolant R-407C.

Electronic control unit

Illuminated 3" display with LCD technology, 70 mm screen diagonal, with clear display of actual and nominal humidity, operating hours, operating state of the chiller unit, the thawing function, the compressor protection function and the operating position for internal 11.5 litre condensation tank. Keys for setting the desired humidity in 1% steps between 30% and 90% as well as for setting the continuous operation. Memory function saves the settings for automatic continuation of operation after a power failure.

Exhaust air set

Generously dimensioned exhaust air hose Ø200mm, 10m long, with metal fastening eyes for hanging up on site, with connecting flange, for distribution of the exhaust air in the room, for dehumidifying cavities, e.g. above intermediate ceilings and for additional blowing of wet surfaces (accessory).

REMS Secco 80 Set

Electric air dehumidifier/building dryer for commercial use. For drying rooms, dehumidifying cellars etc. and drying concrete, masonry, plaster and screed. Chiller unit with rotation compressor and condensation motor 230 V, 50 Hz, 1,200 W, with automatic hot-gas thawing system, for continuous operation. Very quiet running. Dehumidification rate ≤ 80l/24h, air volume ≤ 850m³/h. Electronic control unit with illuminated 3" display and memory function. Electronic hygrostat, operating hours counter, electricity meter. Air filter. In a sturdy sheet steel housing on a mobile tubular steel frame with large castors. In a carton.
Art.-No. 132010 R220 £ 1,640.00

Super offer!

You will get 1 REMS Detect W moisture measuring device free when you buy a REMS Secco 80 set. You have an additional saving of £ 185.00.

132X01 R220 £ **1,390.00**

11.5 litre condensation tank

for discharge of condensation in the sheet steel housing.

Art.-No. 132100 R

£ **39.10**

Exhaust air set

consisting of exhaust air hose Ø200mm, 10m long, with metal fastening eyes for hanging up on site, with connecting flange, for distribution of the exhaust air in the room, for dehumidifying cavities, e.g. above intermediate ceilings and for additional blowing of wet surfaces.

Art.-No. 132104 R

£ **195.00**

REMS Detect W

dielectric moisture measuring device for non-destructive moisture measurement in building materials, e.g. concrete, masonry, plaster, wood

Art.-No. 132115 R

£ **185.00**



Sale through specialist dealers.



REMS (UK) Ltd.

Unit 5 · Ash Industrial Estate
Flex Meadow · Harlow · Essex CM19 5TJ
Phone +44 12 79 41 36 98
Fax +44 12 79 41 37 04
www.rems.de
GBR@rem.de



www.rems.de



www.youtube.com/remstools



www.facebook.com/remstools



www.twitter.com/remstools